

General Description

STARTING/CHARGING SYSTEMS

1. General Description

A: SPECIFICATION

Item		Specifications	
Vehicle model		AT	
Starter	Type	Reduction type	
	Model	428000-5250	
	Manufacturer	DENSO	
	Voltage and output	12 V — 1.6 kW	
	Direction of rotation	Counterclockwise (when observed from pinion)	
	Number of pinion teeth	9	
	No-load characteristics	Voltage	11 V
		Current	90 A or less
		Rotating speed	1,550 rpm or more
	Load characteristics	Voltage	8 V
		Current	370 A
		Torque	12.8 N·m (1.3 kgf·m, 9.4 ft·lb) or more
		Rotating speed	800 rpm or more
	Lock characteristics	Voltage	3 V
Current		750 A or less	
Torque		19.0 N·m (1.9 kgf·m, 14.0 ft·lb) or more	
Generator	Type	Rotating-field three-phase type, voltage regulator built-in type, with load response control system	
	Model	A3TJ3591	
	Manufacturer	Mitsubishi Electric	
	Voltage and output	12 V — 130 A	
	Polarity on ground side	Negative	
	Direction of rotation	Clockwise (when observed from pulley side)	
	Armature connection	3-phase Δ type	
	Output current		1,500 rpm — 55 A or more
			2,500 rpm — 108 A or more
			5,000 rpm — 127 A or more
	Regulated voltage	14.1 — 14.8 V [20°C (68°F)]	
	Rotor slip ring outer diameter	Standard	22.7 mm (0.894 in)
		Limit	22.1 mm (0.870 in)
Brush length	Standard	22.5 mm (0.886 in)	
	Limit	5.0 mm (0.197 in)	
Battery	Type and capacity	12 V — 52 AH (75D 23L)	

B: COMPONENT

1. STARTER

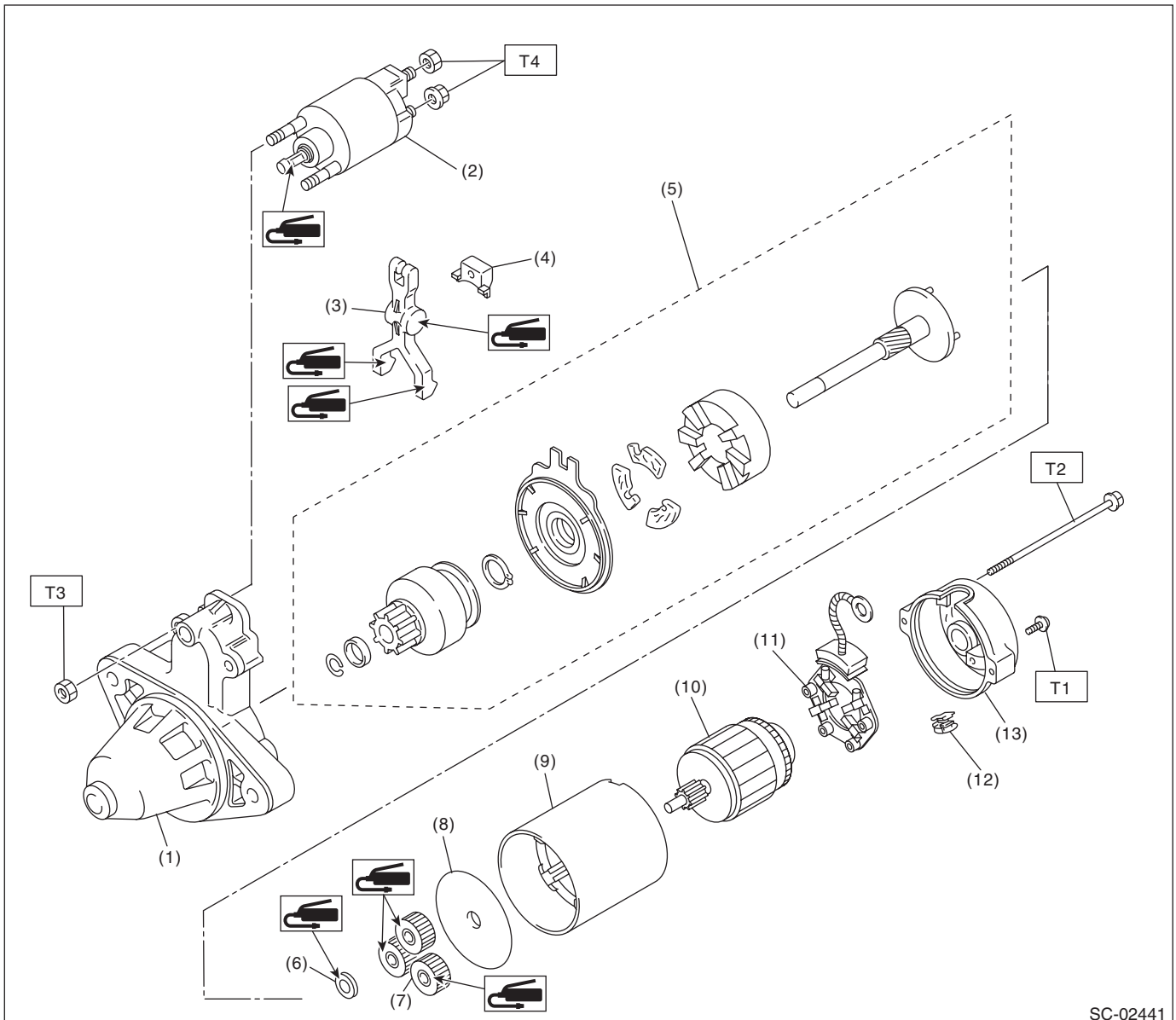

SC-02441

- | | |
|-----------------------------|------------------------|
| (1) Starter housing | (8) Starter plate |
| (2) Magnet switch ASSY | (9) Yoke |
| (3) Shift lever | (10) Armature |
| (4) Starter seal | (11) Brush holder ASSY |
| (5) Overrunning clutch ASSY | (12) Drain duct |
| (6) Washer | (13) Starter cover |
| (7) Planetary gear | |

Tightening torque: N-m (kgf-m, ft-lb)

T1: 1.4 (0.1, 1.0)

T2: 6 (0.6, 4.4)

T3: 7.5 (0.8, 5.5)

T4: 10 (1.0, 7.4)

General Description

STARTING/CHARGING SYSTEMS

2. GENERATOR

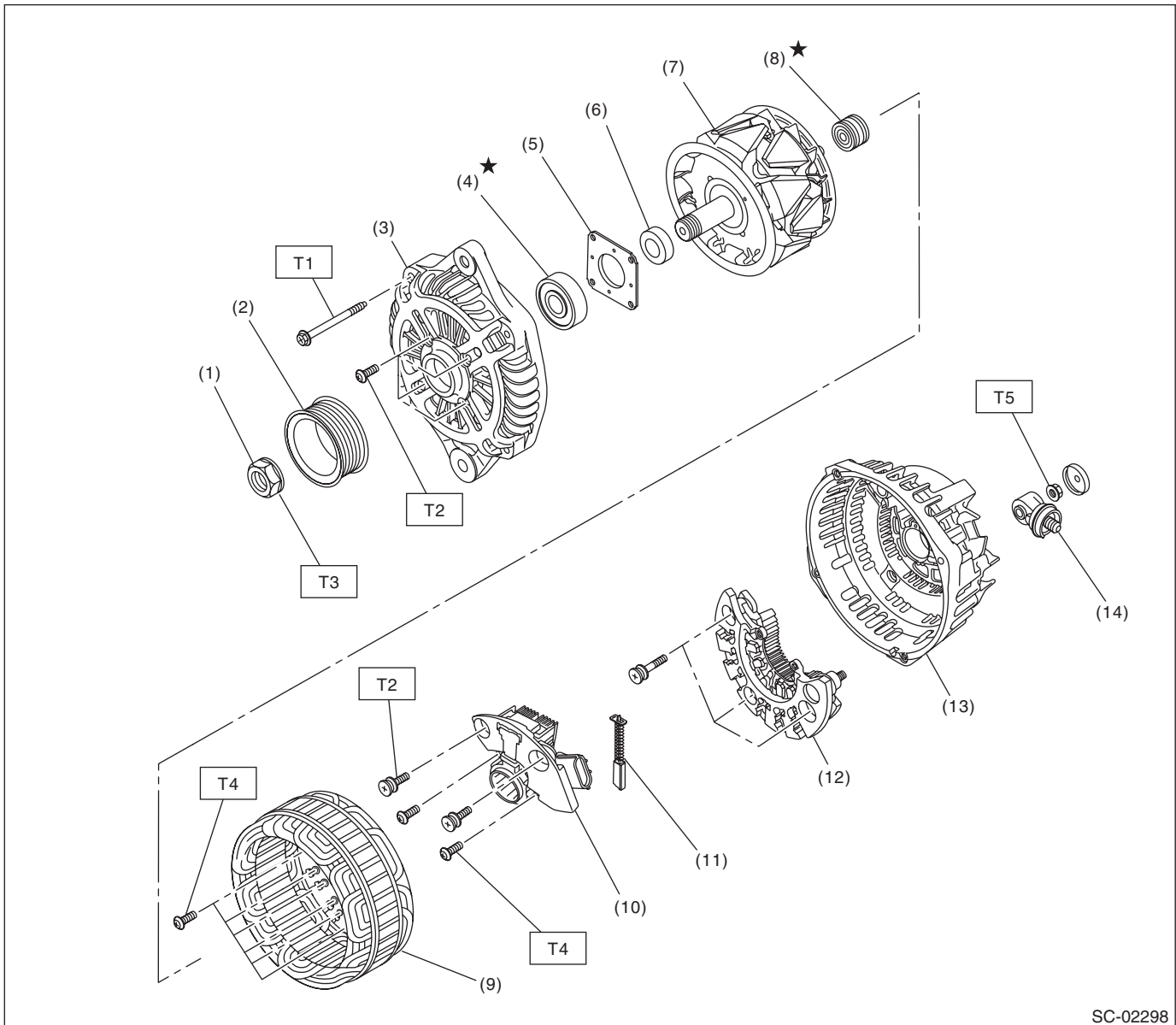

SC-02298

- | | |
|----------------------|-------------------|
| (1) Pulley nut | (8) Bearing |
| (2) Pulley | (9) Stator coil |
| (3) Front cover | (10) IC regulator |
| (4) Ball bearing | (11) Brush |
| (5) Bearing retainer | (12) Rectifier |
| (6) Spacer | (13) Rear cover |
| (7) Rotor | (14) Terminal B |

Tightening torque: N·m (kgf·m, ft·lb)

T1: 4.4 (0.4, 3.2)

T2: 3.9 (0.4, 2.9)

T3: 117.5 (12.0, 86.7)

T4: 2 (0.2, 1.5)

T5: 8.9 (0.9, 6.6)

C: CAUTION

- Prior to starting work, pay special attention to the following:
 1. Always wear work clothes, a safety cap, protective shoes. Additionally, wear a helmet, protective goggles, etc. if necessary.
 2. Protect the vehicle using a seat cover, fender cover, etc.
 3. Prepare the service tools, clean cloth, containers to catch grease and oil, etc.
- Vehicle components are extremely hot immediately after driving. Be wary of receiving burns from heated parts.
- When performing a repair, identify the cause of trouble and avoid unnecessary removal, disassembly and replacement.
- Before disconnecting connectors of sensors or units, be sure to disconnect the ground cable from battery.
- Always use the jack-up point when the shop jacks or rigid racks are used to support the vehicle.
- Remove contamination including dirt and corrosion before removal, installation, disassembly or assembly.
- Keep the removed parts in order and protect them from dust and dirt.
- All removed parts, if to be reused, should be reinstalled in the original positions with attention to the correct directions, etc.
- Bolts, nuts and washers should be replaced with new parts as required.
- Be sure to tighten the fasteners including bolts and nuts to the specified torque.

D: PREPARATION TOOL

1. GENERAL TOOL

TOOL NAME	REMARKS
Circuit tester	Used for measuring resistance, voltage and current.