

Generator

STARTING/CHARGING SYSTEMS

3. Generator

A: REMOVAL

- 1) Remove the collector cover.
- 2) Disconnect the ground cable from battery.
- 3) Disconnect the connector and terminal B from the generator, and remove the harness cover from the collector cover bracket.

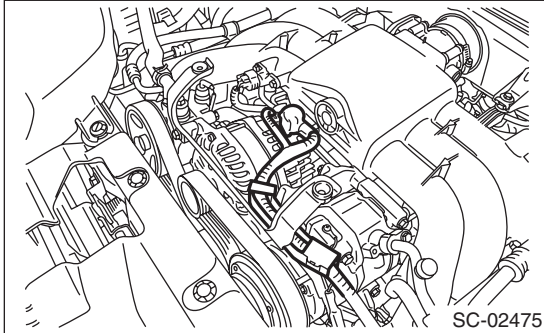

- 4) Remove the V-belts. <Ref. to ME(H6DO)-46, REMOVAL, V-belt.>
- 5) Remove the collector cover bracket.

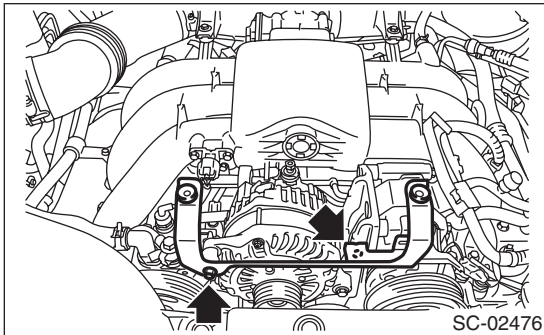

- 6) Remove the generator.

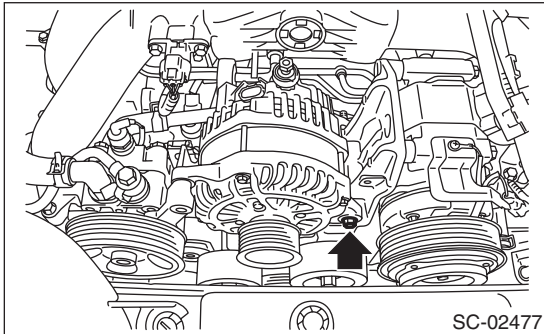

B: INSTALLATION

Install in the reverse order of removal.

CAUTION:

Check and adjust the V-belt tension. <Ref. to ME(H6DO)-46, INSPECTION, V-belt.>

Tightening torque:

25 N·m (2.5 kgf-m, 18.4 ft-lb)

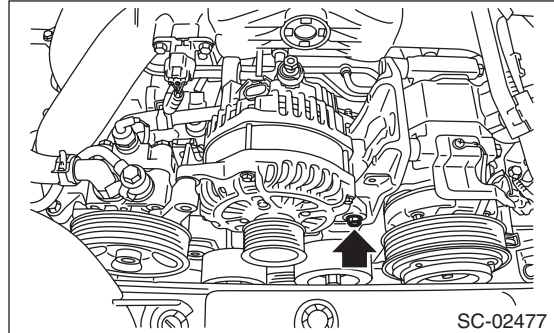

Tightening torque:

T1: 6.4 N·m (0.7 kgf-m, 4.7 ft-lb)

T2: 25 N·m (2.5 kgf-m, 18.4 ft-lb)

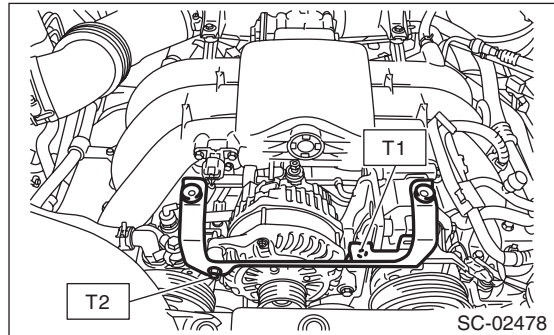

Tightening torque:

16 N·m (1.6 kgf-m, 11.8 ft-lb)

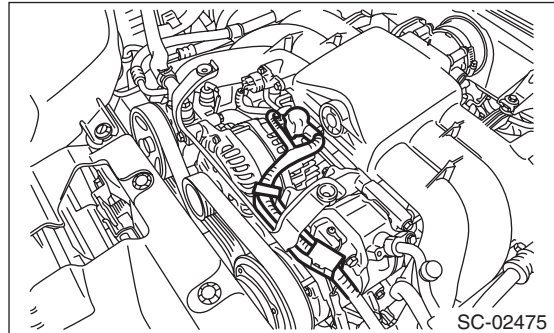

C: DISASSEMBLY

1) Remove the four through bolts.

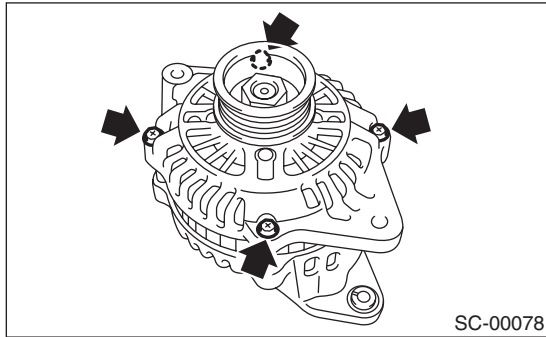

2) Use a drier to heat the rear cover (A) portion to 50 — 60°C (122 — 140°F).

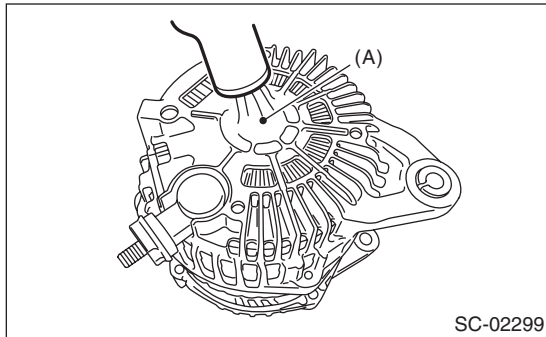

3) Insert the end of a flat tip screwdriver into the gap between stator core and front cover. Pry them apart to disassemble.

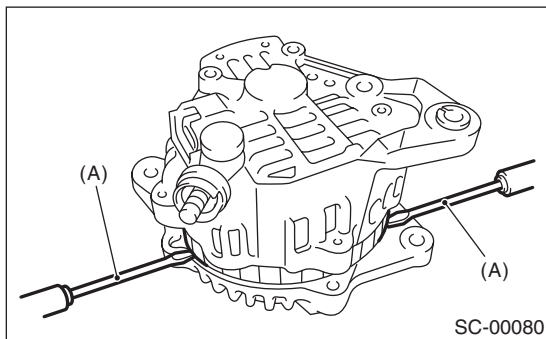

(A) Screwdriver

4) Using a vise, support the rotor and remove the pulley nut, then remove the rotor from the front cover.

CAUTION:

When holding the rotor with a vise, place aluminum plates or wooden pieces on the vise jaws to prevent rotor from damage.

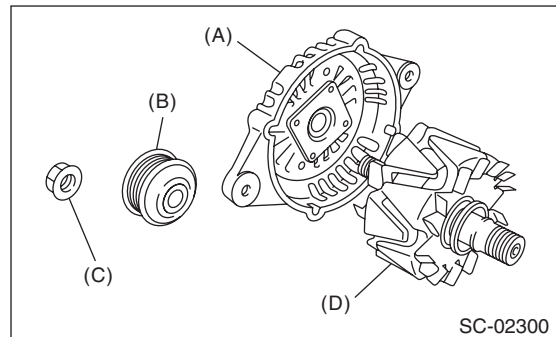
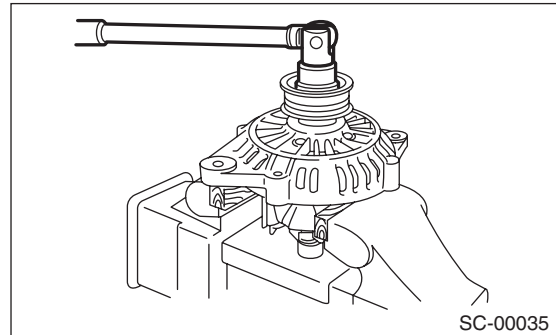

(A) Front cover
 (B) Pulley
 (C) Pulley nut
 (D) Rotor

5) Use the following procedures to remove the ball bearings.

(1) Remove the bolt, and then detach the bearing retainer.

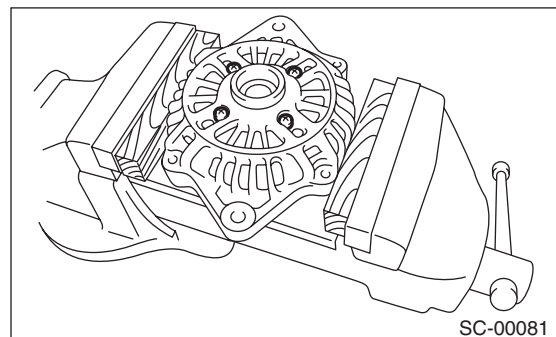

Generator

STARTING/CHARGING SYSTEMS

(2) Firmly attach an appropriate tool (such as a correct size socket wrench) to the bearing inner race.

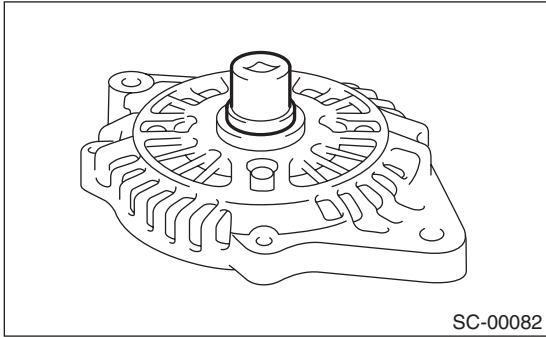

(3) Use the press to push the ball bearings out from the front cover.

6) Using the bearing puller, remove the bearings from the rotor.

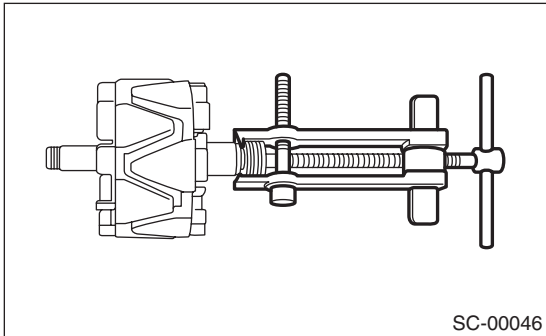

7) Remove six bolts between the rectifier and stator coil, then remove the stator coil.

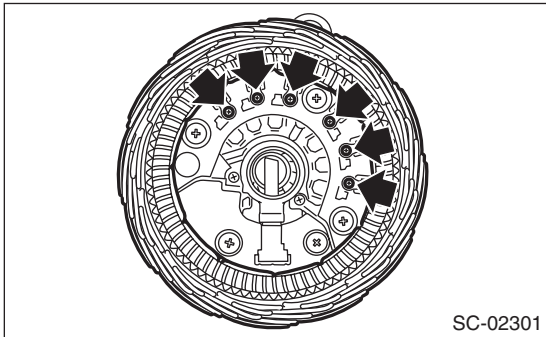

8) Remove four screws which secure the IC regulator to the rear cover, then remove the IC regulator.

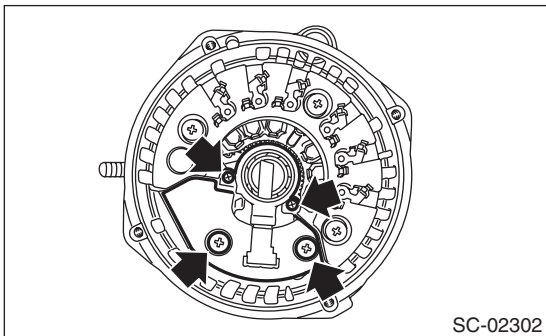

9) Use the following procedures to remove the brush.

(1) Remove the cover A.

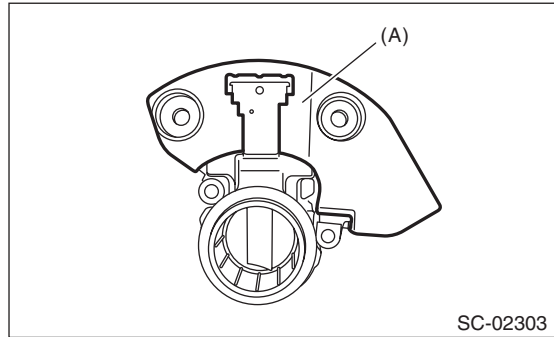

(A) Cover A

(2) Remove the cover B.

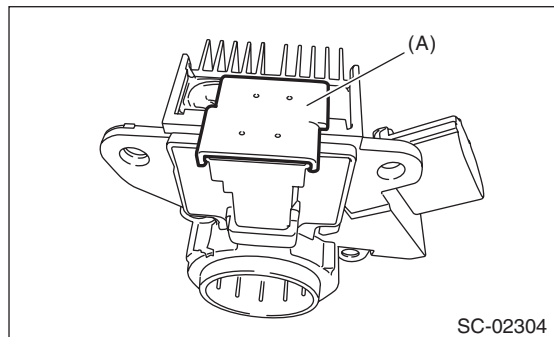

(A) Cover B

(3) Disconnect the connection and remove the brush.

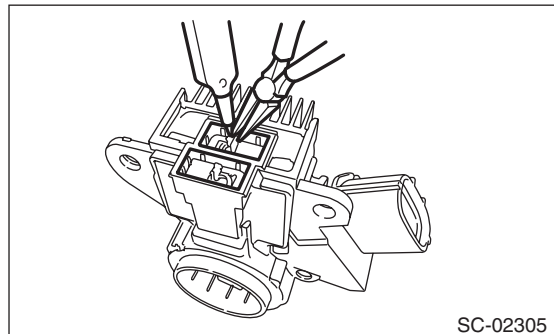

10) Remove the rectifier as follows.

(1) Remove the cover on terminal B.

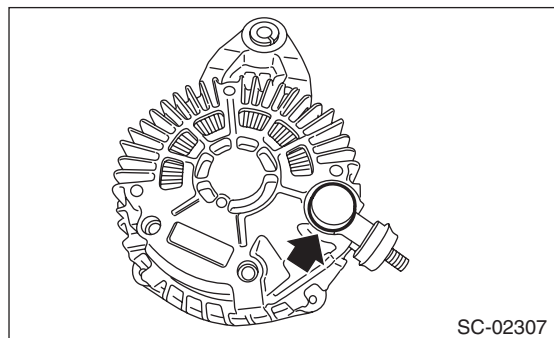

(2) Remove the nut on terminal B.

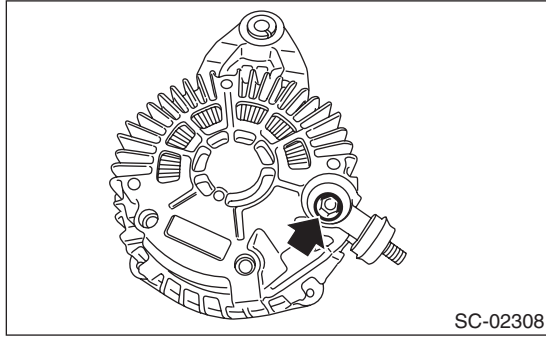

(3) Remove the bolts which secure the rectifier, and remove the rectifier.

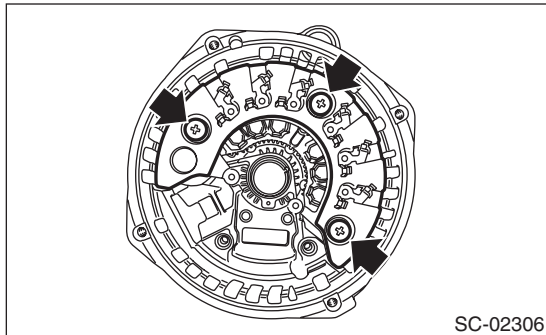

D: ASSEMBLY

Assemble in the reverse order of disassembly.

NOTE:

- Refer to component for tightening torque of each part. <Ref. to SC(H6DO)-4, GENERATOR, COMPONENT, General Description.>
- After assembling, manually turn the pulley to check that the rotor rotates smoothly.

1) Push of the brush

Before assembling the front and rear parts, press the brush down into the brush holder, then fix the brush in that position by inserting a [1 mm (0.08 in) dia., 40 — 50 mm (1.6 — 2.0 in) long] wire through the hole as shown in the figure.

CAUTION:

After re-assembling, remove the wire.

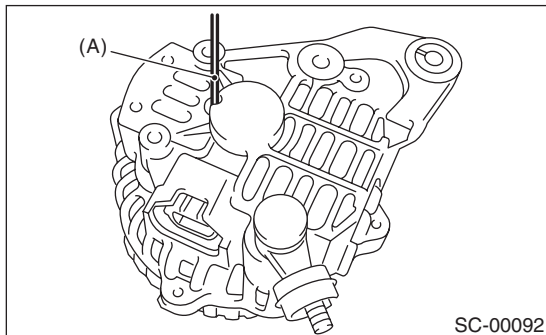

(A) Wire

2) Install the ball bearings.

(1) Set the ball bearings in the front cover, then securely install an appropriate tool (such as a socket wrench of proper size) to the bearing outer race.

(2) Using a press to press the ball bearings into the specified location.

(3) Install the bearing retainer.

3) Install the bearings.

CAUTION:

Do not apply grease to the bearings. If there is any oil on the bearing box, remove it completely.

(1) Use a press to install the bearings to the rotor shaft.

(2) Heat the bearing box in rear cover at 50 to 60°C (122 to 140°F), and then press the bearing into rear cover.

E: INSPECTION

1. DIODE

CAUTION:

There is the possibility of damaging the diodes if a mega-tester (used to measure high voltages) or a similar measuring instrument is used. Never use a mega tester or equivalent for this test.

1) Check for continuity between the diode lead and terminal E or B. If continuity is not as shown in the table, replace the rectifier.

- At analog type tester

Tester lead		Continuity
-lead	+lead	
E	P1, P2, P3, P4, P5, P6	Yes
B		No
P1, P2, P3, P4, P5, P6	E	No
	B	Yes

Generator

STARTING/CHARGING SYSTEMS

- At digital type tester

Tester lead		Continuity
-lead	+lead	
E	P1, P2, P3, P4, P5, P6	No
B		Yes
P1, P2, P3, P4, P5, P6	E	Yes
	B	No

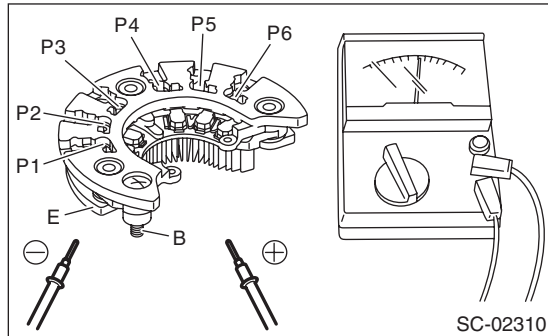

2. ROTOR

- 1) Inspect the slip rings for contamination or any roughness on the sliding surface. Repair the slip ring surface using a lathe or sand paper.
- 2) Measure the slip ring outer diameter. Replace the rotor if the slip ring is worn.

Slip ring outer diameter:

Standard

22.7 mm (0.894 in)

Limit

22.1 mm (0.870 in)

- 3) Using a circuit tester, check the resistance between slip rings. If resistance exceeds the standard, replace the rotor.

Standard:

Approx. 2.0 — 2.3 Ω

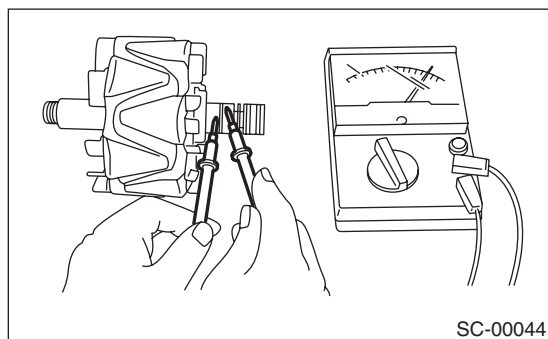

- 4) Check the continuity between slip ring and rotor core or shaft. If there is continuity, replace the rotor because the rotor coil is grounded.

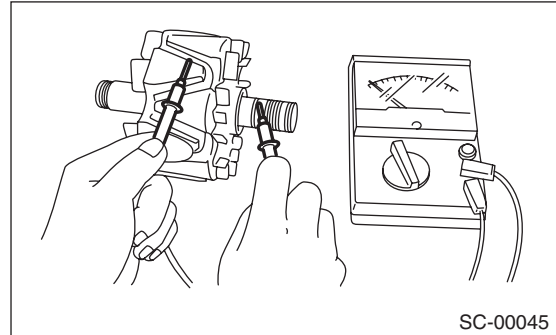

- 5) Check the bearings. If there is any noise, or the rotor does not rotate smoothly, replace the bearings.

3. STATOR COIL

- 1) Inspect the continuity between the stator coil terminals. If continuity is not as shown in the table, replace the stator coil.

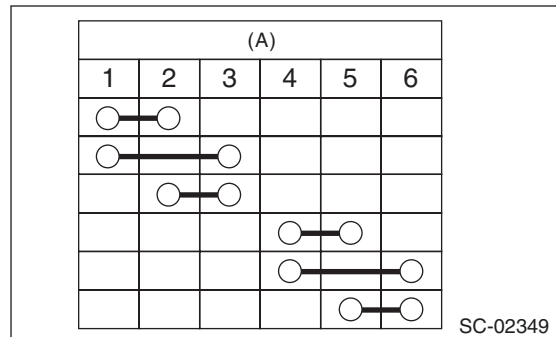

(A) Terminals

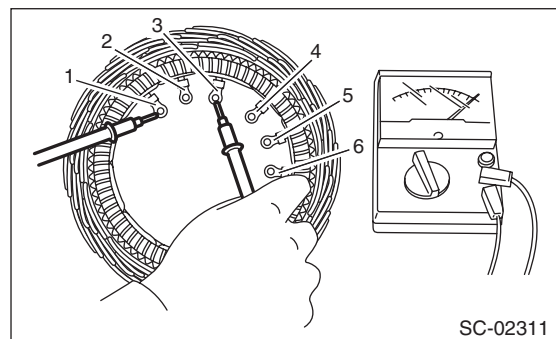

2) Inspect the continuity between the stator coil stator core and lead wire terminals. If there is continuity, replace the stator coil because the stator coil is grounded.

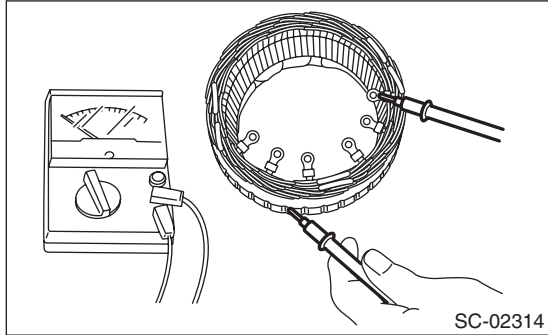

4. BRUSH

1) Measure the length of each brush. Replace the brush if wear exceeds service limits. There is a service limit mark (A) on each brush.

Brush length:

Standard (1)

22.5 mm (0.886 in)

Limit (2)

5.0 mm (0.197 in)

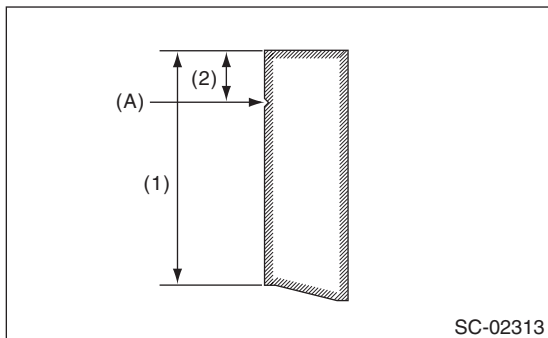

2) Using a spring pressure indicator, push the brush into the brush holder until its tip protrudes 2 mm (0.08 in). Then measure the pressure of brush spring. If the pressure is 1.7 N (173 gf, 6.11 ozf) or less, replace the brush spring. 4.1 — 5.3 N (418 — 540 gf, 14.75 — 19.06 ozf) pressure is required on the new spring.

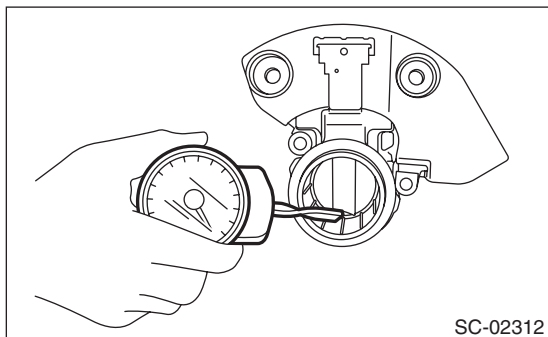

5. BALL BEARING

Check the ball bearings. Replace the ball bearings if there is resistance in the rotation, or if there is any abnormal noise.

6. OTHER INSPECTIONS

Check that the generator does not have deformation, cracks and any other damage.