

This manual provides information on the electrical circuits installed on vehicles by dividing them into a circuit for each system.

The actual wiring of each system circuit is shown from the point where the power source is received from the battery as far as each ground point. (All circuit diagrams are shown with the switches in the OFF position.)

When troubleshooting any problem, first understand the operation of the circuit where the problem was detected (see System Circuit section), the power source supplying power to that circuit (see Power Source section), and the ground points (see Ground Points section). See the System Outline to understand the circuit operation.

When the circuit operation is understood, begin troubleshooting of the problem circuit to isolate the cause. Use Relay Location and Electrical Wiring Routing sections to find each part, junction block and wiring harness connectors, wiring harness and wiring harness connectors, splice points, and ground points of each system circuit. Internal wiring for each junction block is also provided for better understanding of connection within a junction block.

Wiring related to each system is indicated in each system circuit by arrows (from\_\_\_, to\_\_\_). When overall connections are required, see the Overall Electrical Wiring Diagram at the end of this manual.

## B HOW TO USE THIS MANUAL

\* The system shown here is an EXAMPLE ONLY. It is different to the actual circuit shown in the SYSTEM CIRCUITS SECTION.

### POWER WINDOW

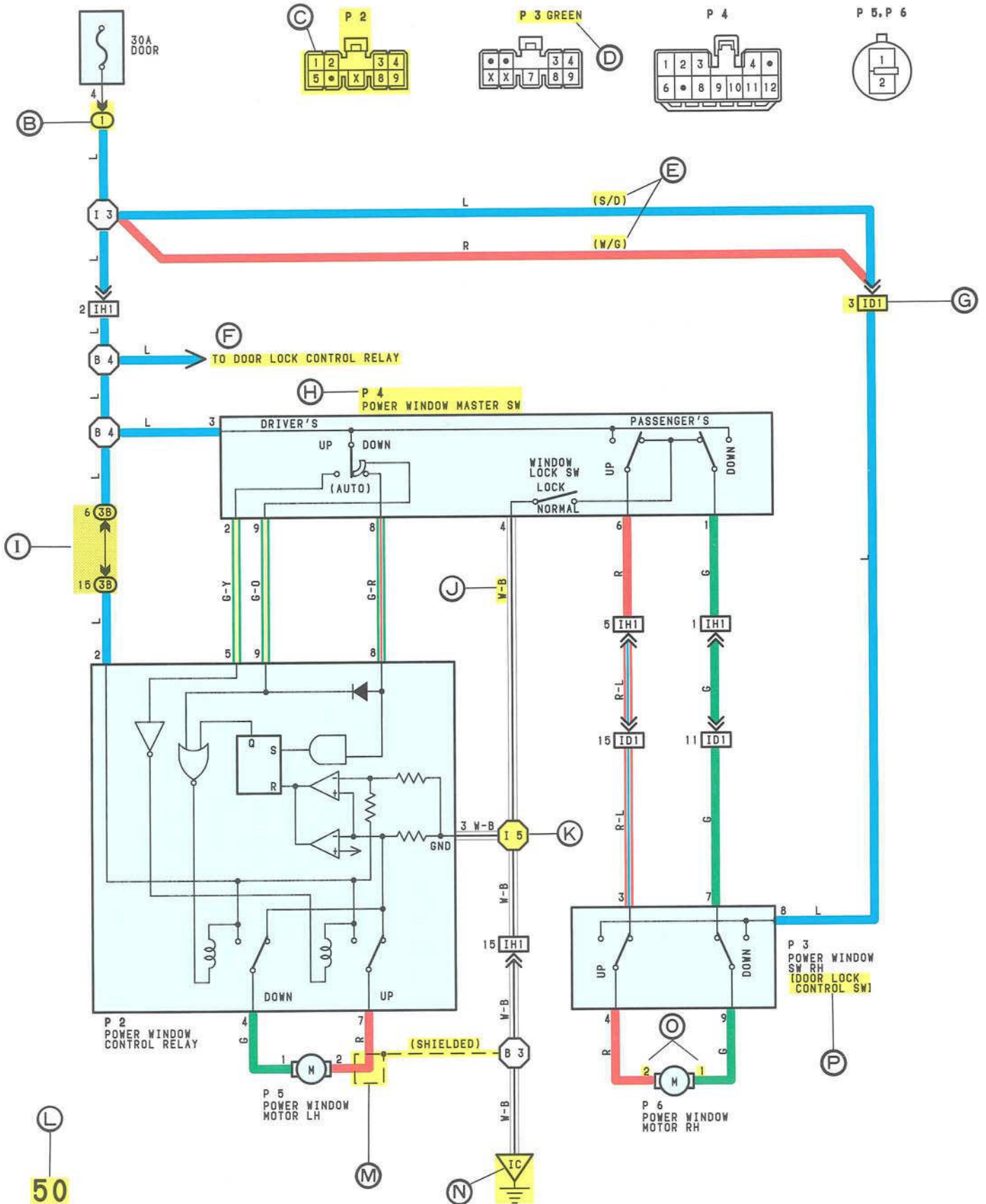

- (A): System Title
- (B): Indicates a Relay Block. No shading is used and only the Relay Block No. is shown to distinguish it from the J/B.
- Example: ① Indicates Relay Block No. 1.
- (C): Indicates the connector to be connected to a part (the numeral indicates the pin No.)

Explanation of pin use.

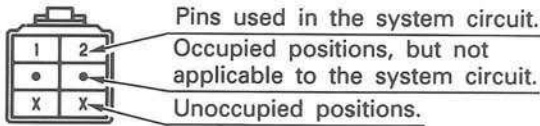

The pins shown are only for the highest grade, or only include those in the specification.

- (D): Connector Color  
Connectors not indicated are milky white in color.
- (E): ( ) is used to indicate different wiring and connector, etc. when the vehicle model, engine type, or specification is different.
- (F): Indicates related system.
- (G): Indicates the wiring harness and wiring harness connector. The wiring harness with male terminal is shown with arrows (↗). Outside numerals are pin numbers.

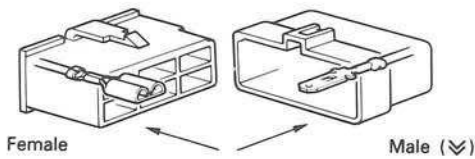

The first letter of the code for each wiring harness and wiring harness connector(s) indicates the component's location, e.g., "E" for the Engine Compartment, "I" for the Instrument Panel and Surrounding area, and "B" for the Body and Surrounding area.

When more than one code has the first and second letters in common, followed by numbers (e.g., IH1, IH2), this indicates the same type of wiring harness and wiring harness connector.

- (H): Represents a part (all parts are shown in sky blue). The code is the same as the code used in parts position.
- (I): Junction Block (The number in the circle is the J/B No. and the connector code is shown beside it). Junction Blocks are shaded to clearly separate them from other parts.

Example:

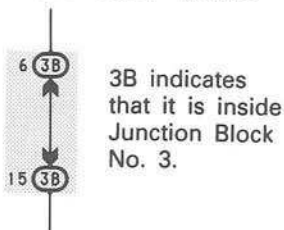

- (J): Indicates the wiring color.  
Wire colors are indicated by an alphabetical code.

B = Black	L = Blue	R = Red
BR = Brown	LG = Light Green	V = Violet
G = Green	O = Orange	W = White
GR = Gray	P = Pink	Y = Yellow

The first letter indicates the basic wire color and the second letter indicates the color of the stripe.

Example: L - Y

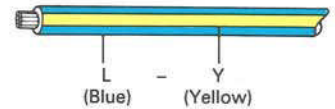

- (K): Indicates a wiring Splice Point (Codes are "E" for the Engine Room, "I" for the Instrument Panel, and "B" for the Body).

Example:

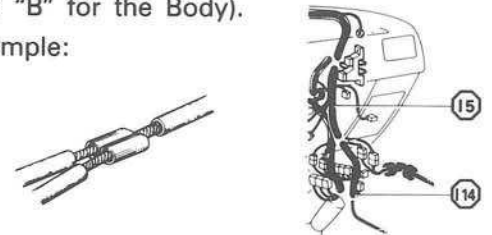

The Location of Splice Point I 5 is indicated by the shaded section.

- (L): Page No.
- (M): Indicates a shielded cable.



- (N): Indicates a ground point.  
The first letter of the code for each ground point(s) indicates the component's location, e.g., "E" for the Engine Compartment, "I" for the Instrument Panel and Surrounding area, and "B" for the Body and Surrounding area.
- (O): Indicates the pin number of the connector. The numbering system is different for female and male connectors.

Example: Numbered in order from upper left to lower right      Numbered in order from upper right to lower left

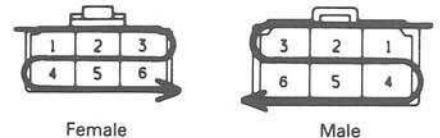

- (P): When 2 parts both use one connector in common, the parts connector name used in the wire routing section is shown in square brackets [ ].

## B HOW TO USE THIS MANUAL

Q

### SYSTEM OUTLINE

WITH THE IGNITION SW TURNED ON, THE CURRENT FLOWS TO TERMINAL 3 OF THE POWER WINDOW MASTER SW, TERMINAL 2 OF THE POWER WINDOW CONTROL RELAY AND TERMINAL 8 OF THE POWER WINDOW SW THROUGH THE DOOR FUSE.

#### 1. DRIVER'S WINDOW "MANUAL UP" OPERATION BY MASTER SW

HOLDING MANUAL SW(DRIVER'S) ON "UP" POSITION LOCATED IN POWER WINDOW MASTER SW, THE CURRENT FLOWS TO TERMINAL 5 OF THE POWER WINDOW CONTROL RELAY THROUGH TERMINAL 3 OF THE MASTER SW → TERMINAL 2 TO OPERATE A POWER WINDOW CONTROL RELAY. THUS THE CURRENT INSIDE THE RELAY FLOWS FROM TERMINAL 2 OF THE RELAY → TERMINAL 1 → TERMINAL 2 OF THE POWER WINDOW MOTOR → TERMINAL 1 → TERMINAL 4 OF THE RELAY → TERMINAL 3 → TO GROUND. THE MOTOR TURNS TO ASCENT THE WINDOW. RELEASING THIS SW, THE ROTATION OF MOTOR IS STOPPED AND THE WINDOWS CAN STOP AT WILL POINT.

(FOR THE "MANUAL DOWN" OPERATION, CURRENT FLOWS IN THE REVERSE DIRECTION BECAUSE THE TERMINALS WHERE IT FLOWS ARE CHANGED).

#### 2. DRIVER'S WINDOW "AUTO DOWN" OPERATION BY MASTER SW

ONCE THE "AUTO DOWN" BUTTON OF THE MASTER SW IS PUSHED, THE CURRENT FLOWS THROUGH TERMINAL 9 OF THE POWER WINDOW CONTROL RELAY THROUGH TERMINAL 3 OF THE MASTER SW → TERMINALS 8 AND 9 TO OPERATE THE RELAY. THUS THE CURRENT INSIDE THE POWER WINDOW CONTROL RELAY FLOWS FROM TERMINAL 2 OF THE RELAY → TERMINAL 4 → TERMINAL 1 OF THE POWER WINDOW MOTOR → TERMINAL 2 → TERMINAL 1 OF THE RELAY → TERMINAL 3 → TO GROUND. THE MOTOR CONTINUES THE ROTATION ENABLING TO DESCENT THE WINDOW.

THE WINDOW DESCENDS TO THE END POSITION, THE CURRENT WILL BE CUT OFF TO RELEASE THE AUTO DOWN FUNCTION BASED ON THE INCREASING CURRENT BETWEEN TERMINAL 2 OF THE RELAY AND TERMINAL 1 IN RELAY.

#### 3. DRIVER'S WINDOW AUTO DOWN RELEASE OPERATION BY MASTER SW

HOLDING THE MANUAL SW(DRIVER'S) ON "UP" POSITION IN OPERATING AUTO DOWN, THE CURRENT FROM TERMINAL 3 OF THE MASTER SW PASSING TERMINAL 2 FLOWS TERMINAL 5 OF THE RELAY AND RELEASES THE AUTO DOWN FUNCTION IN THE POWER WINDOW CONTROL RELAY. RELEASING THE HAND FROM SW, WINDOW STOPS AND CONTINUING ON TOUCHING SW, THE FUNCTION SWITCHES TO MANUAL UP OPERATION.

#### 4. PASSENGER'S WINDOW UP OPERATION(MASTER SW) AND WINDOW LOCK SW OPERATION

HOLDING PASSENGER'S WINDOW SW(MASTER SW) ON "UP", THE CURRENT FLOWS FROM TERMINAL 3 OF THE MASTER SW PASSING TERMINAL 6 TO TERMINAL 3 OF THE POWER WINDOW SW(PASSENGER'S) → TERMINAL 4 → TERMINAL 2 OF THE MOTOR → TERMINAL 1 → TERMINAL 9 OF THE POWER WINDOW SW → TERMINAL 7 → TERMINAL 1 OF THE MASTER SW → TERMINAL 4 TO GROUND. THE MOTOR RUNS TO ASCENT THE WINDOW. RELEASING THIS SW, THE ROTATION OF MOTOR IS STOPPED AND WINDOW CAN STOP AT WILL PLACE. SWITCHING THE WINDOW LOCK SW IN "LOCK" POSITION, THE CIRCUIT IS OPENED AND STOPPED THE MOTOR ROTATION.

(FOR THE DOWN OPERATION, CURRENT FLOWS IN THE REVERSE DIRECTION BECAUSE THE TERMINALS WHERE IT FLOWS ARE CHANGED).

R

### SERVICE HINTS

#### P2 POWER WINDOW CONTROL RELAY

3-GROUND:ALWAYS CONTINUITY

2-GROUND:APPROX.12VOLTS WITH IGNITION SW AT ON POSITION

5-GROUND:APPROX.12VOLTS WITH IGNITION SW AT ON POSITION AND MASTER SW AT UP POSITION

8-GROUND:APPROX.12VOLTS WITH IGNITION SW AT ON POSITION AND MASTER SW AT AUTO DOWN POSITION

9-GROUND:APPROX.12VOLTS WITH IGNITION SW AT ON POSITION AND MASTER SW AT DOWN OR AUTO DOWN POSITION

#### P4 POWER WINDOW MASTER SW

4-GROUND:ALWAYS CONTINUITY

3-GROUND:APPROX.12VOLTS WITH IGNITION SW AT ON POSITION

#### WINDOW LOCK SW

OPEN WITH WINDOW LOCK SW AT LOCK POSITION

S

### ○ : PARTS LOCATION

CODE	SEE PAGE	CODE	SEE PAGE	CODE	SEE PAGE
P2	21	P4	21	P6	21
P3	21	P5	21		

T

### ○ : RELAY BLOCKS

CODE	SEE PAGE	RELAY BLOCK (RELAY BLOCK LOCATION)
1	16	R/B NO.1 (INSTRUMENT PANEL LEFT SIDE)

U

### ○ : JUNCTION BLOCK AND WIRE HARNESS CONNECTOR

CODE	SEE PAGE	JUNCTION BLOCK AND WIRE HARNESS (CONNECTOR LOCATION)
3B	14	J/B NO.3 AND COWL WIRE (INSTRUMENT PANEL LEFT SIDE)

V

### □ : CONNECTOR JOINING WIRE HARNESS AND WIRE HARNESS

CODE	SEE PAGE	JOINING WIRE HARNESS AND WIRE HARNESS (CONNECTOR LOCATION)
ID1	26	FRONT DOOR RH WIRE AND COWL WIRE (RIGHT KICK PANEL)
IH1	26	FRONT DOOR LH WIRE AND COWL WIRE (LEFT KICK PANEL)

W

### ▽ : GROUND POINTS

CODE	SEE PAGE	GROUND POINT LOCATION
IC	24	COWL LEFT

X

### ○ : SPLICE POINTS

CODE	SEE PAGE	WIRE HARNESSES WITH SPLICE POINTS
15	24	COWL WIRE

- Ⓚ: Explains the system outline.
- Ⓡ: Indicates values or explains the function for reference during troubleshooting.
- Ⓢ: Indicates the reference page showing the position on the vehicle of the parts in the system circuit.  
 Example: Part "P4" (Power Window Master SW) is on page 21 of the manual.  
 \* The letter in the code is from the first letter of the part, and the number indicates its order in parts starting with that letter.  
 Example: P4  
 └─── Part is 4th in order  
 └─── Power Window Master SW
- Ⓣ: Indicates the reference page showing the position on the vehicle of Relay Block Connectors in the system circuit.  
 Example: Connector "1" is described on page 16 of this manual and is installed on the left side of the instrument panel.
- Ⓤ: Indicates the reference page showing the position on the vehicle of J/B and Wire Harness in the system circuit.  
 Example: Connector "3B" connects the Cowl Wire and J/B No. 3. It is described on page 14 of this manual, and is installed on the instrument panel left side.
- Ⓥ: Indicates the reference page describing the wiring harness and wiring harness connector (the female wiring harness is shown first, followed by the male wiring harness).  
 Example: Connector "ID1" connects the front door RH wire (female) and cowl wire (male). It is described on page 26 of this manual, and is installed on the right side kick panel.
- Ⓦ: Indicates the reference page showing the position of the ground points on the vehicle.  
 Example: Ground point "IC" is described on page 24 of this manual and is installed on the cowl left side.
- Ⓧ: Indicates the reference page showing the position of the splice points on the vehicle.  
 Example: Splice point "I 5" is on the Cowl Wire Harness and is described on page 24 of this manual.

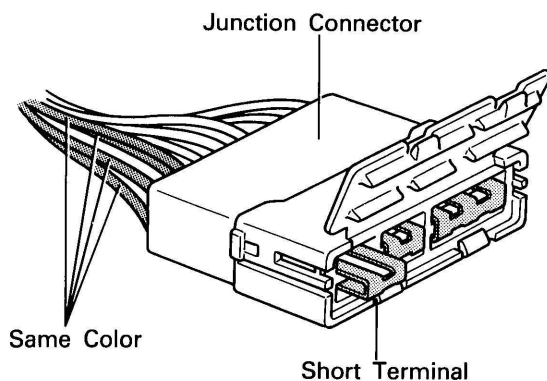
**HINT:**

Junction connector (code: J1 to J37) in this manual include a short terminal which is connected to a number of wire harnesses. Always perform inspection with the short terminal installed. (When installing the wire harnesses, the harnesses can be connected to any position within the short terminal grouping. Accordingly, in other vehicles, the same position in the short terminal may be connected to a wire harness from a different part.)  
 Wire harness sharing the same short terminal grouping have the same color.

## B HOW TO USE THIS MANUAL

The "Current Flow Chart" section, describes which parts each power source (fuses, fusible links, and circuit breakers) transmits current to. In the Power Source circuit diagram, the conditions when battery power is supplied to each system are explained. Since all System Circuit diagrams start from the power source, the power source system must be fully understood.

### H POWER SOURCE (Current Flow Chart)

The chart below shows the route by which current flows from the battery to each electrical source (Fusible Link, Circuit Breaker, Fuse, etc.) and other parts.

The next page and following pages show the parts to which each electrical source outputs current.

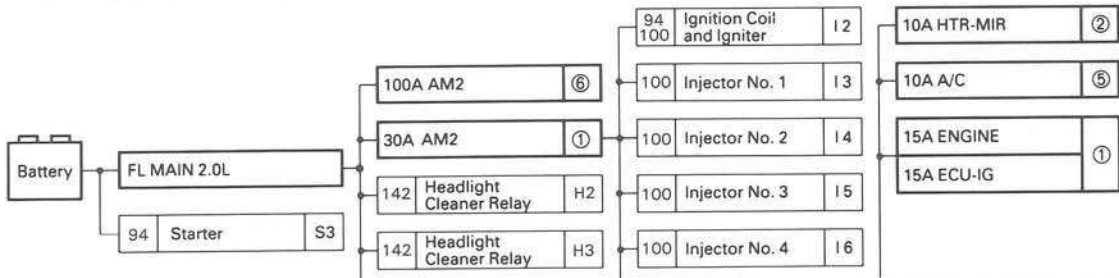

Page Nos. of Related Systems		200	100	98	190	200	200	124	200	186	190	124	136	136	200	200	136	136	112	100	154	124	100		
Location	Parts																								
	Code or Location																								
CB or Fuse		A1	A4	A5	A7	A8	A9	A10	A11	A12	A13	B1	B3	B4	B5	R5	R6	C2	C3	C8	C8	C9			
10A	ENGINE			●																					
20A	WIPER																								
10A	TURN																								
10A	CAUSE																								

### POWER SOURCE

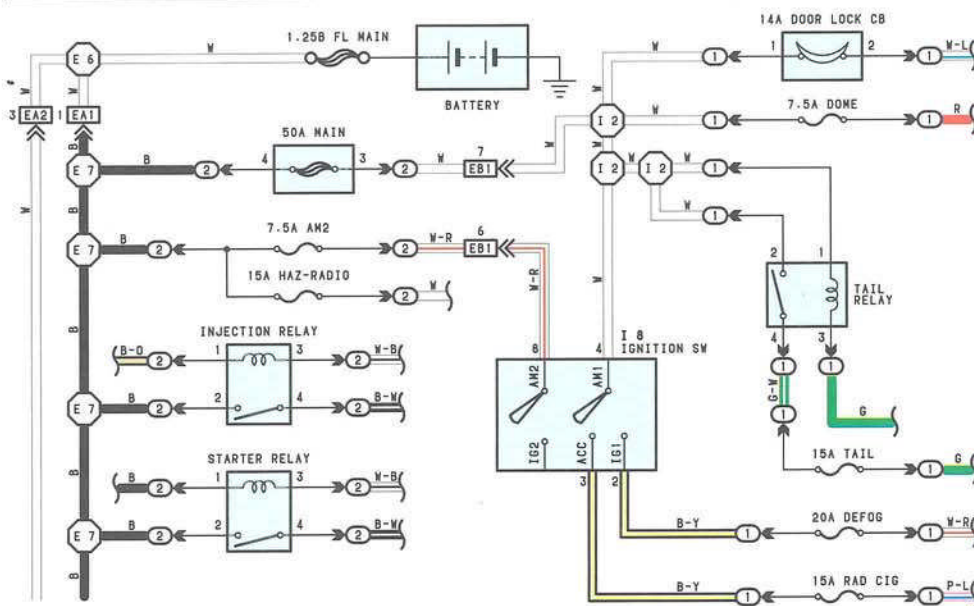

The ground points circuit diagram shows the connections from all major parts to the respective ground points. When troubleshooting a faulty ground point, checking the system circuits which use a common ground may help you identify the problem ground quickly. The relationship between ground points (EA, IB and IC shown below) can also be checked this way.

## J GROUND POINT

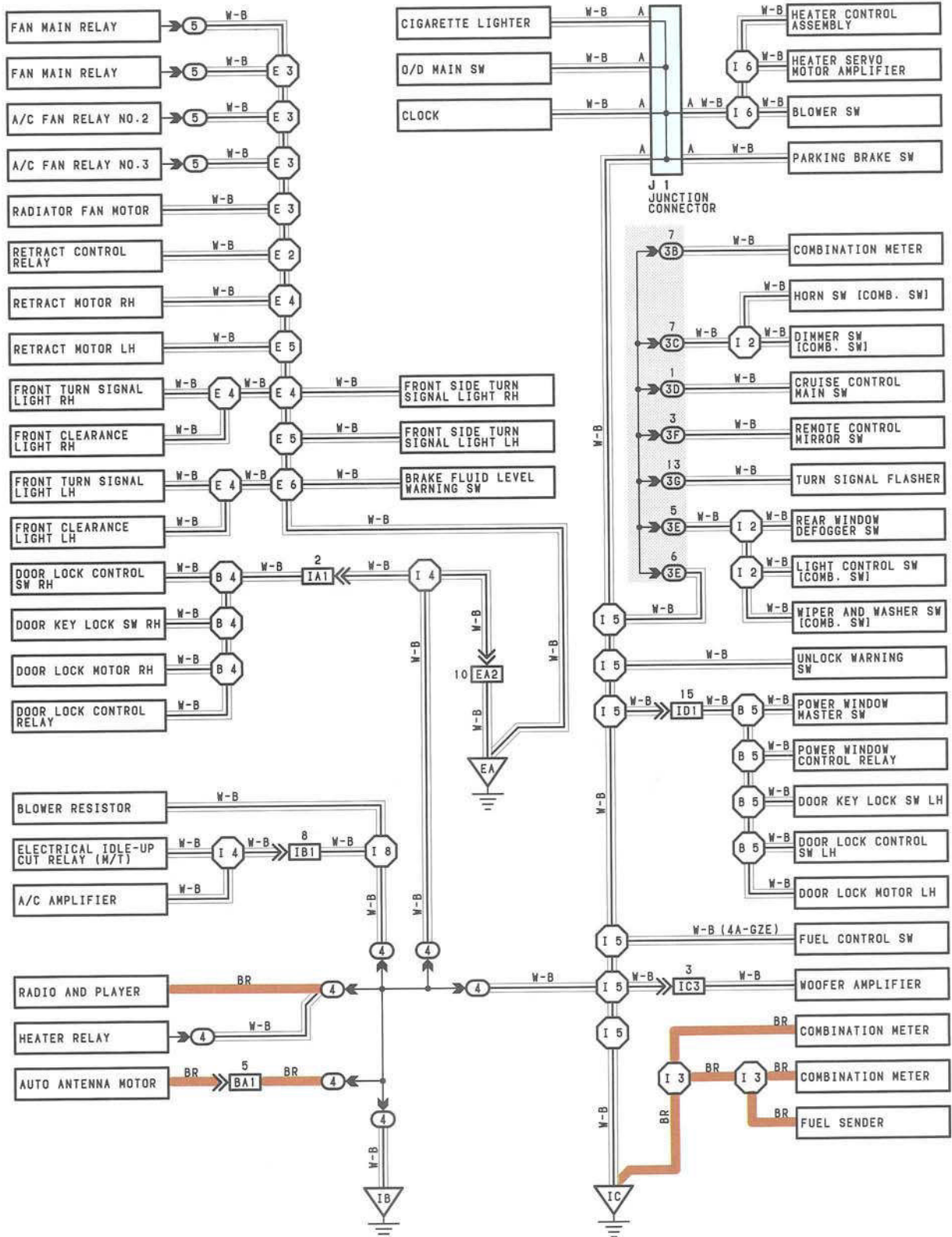

\* The system shown here is an EXAMPLE ONLY. It is different to the actual circuit shown in the SYSTEM CIRCUITS SECTION.