

Starter Relay Circuit

CIRCUIT DESCRIPTION

When the theft deterrent system is activated, contact (a) in the ECU becomes open, creating an open circuit in terminal SRLY circuit and making the starter inoperative (starter cut).

In this condition, if one of the following operations is done, the contact (a) in the ECU is grounded, thus canceling the starter cut:

- (1) Unlock the front LH or RH door with key.
- (2) Unlock the doors with the wireless door lock control system.

WIRING DIAGRAM

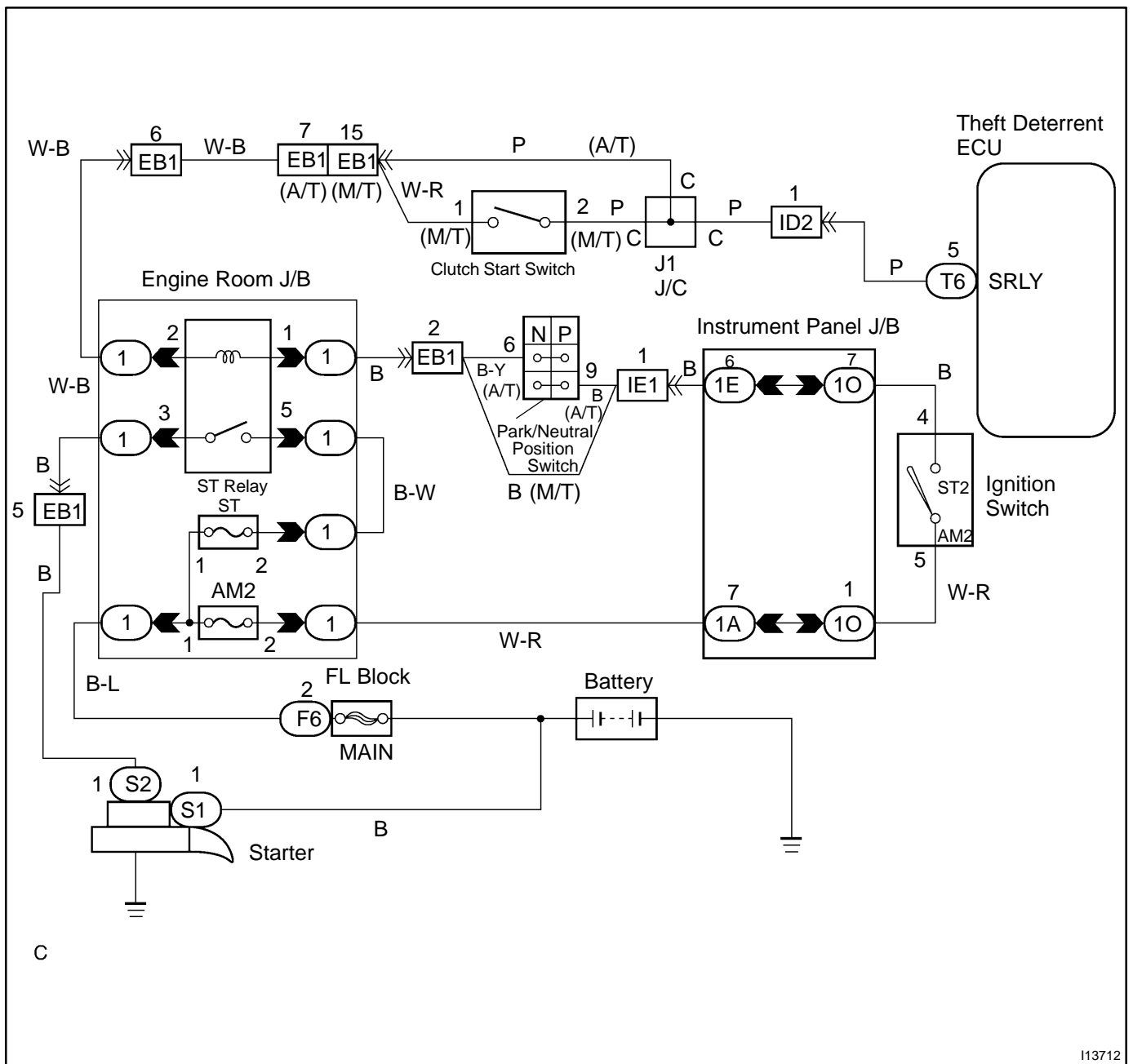

INSPECTION PROCEDURE

HINT:

This troubleshooting is based on the premise that engine cranking occurs.

If the engine does not crank, proceed to the engine troubleshooting on [DI-1](#).

1	Check voltage between terminal SRLY of theft deterrent ECU connector and body ground.
----------	--

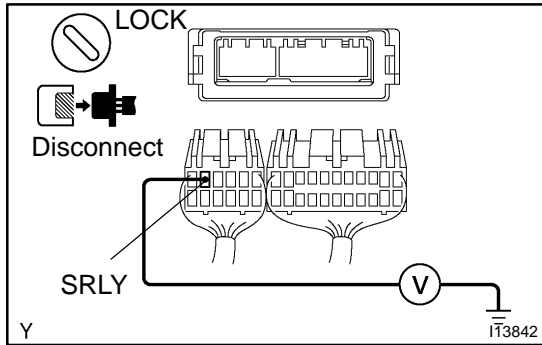

PREPARATION:

- (a) Disconnect the theft deterrent ECU connector.
- (b) Transmission in neutral position.

CHECK:

Measure voltage between terminal SRLY of theft deterrent ECU connector and body ground, when ignition switch is turned to ST position.

OK:

Voltage: 10 - 14 V

OK	Check and repair theft deterrent ECU.
-----------	--

NG

Check and repair harness and connector between starter and theft deterrent ECU (See page IN-29).
