

DISASSEMBLY

1. INSPECT 3RD AND 4TH GEARS THRUST CLEARANCE

Using a feeler gauge, measure the thrust clearance.

Standard clearance:

3rd gear: 0.10 - 0.35 mm (0.0039 - 0.0138 in.)

4th gear: 0.10 - 0.55 mm (0.0039 - 0.0217 in.)

Maximum clearance:

3rd gear: 0.35 mm (0.0138 in.)

4th gear: 0.55 mm (0.0217 in.)

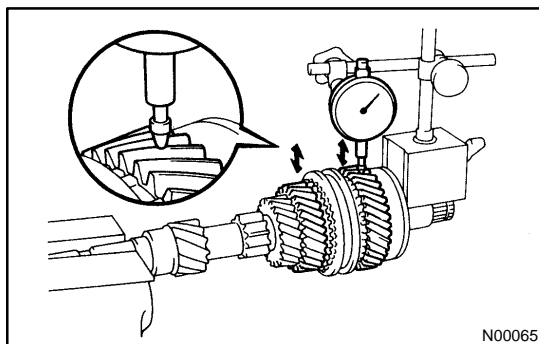

2. INSPECT 3RD AND 4TH GEARS RADIAL CLEARANCE

Using a dial indicator, measure the radial clearance between the gear and shaft.

Standard clearance:

KOYO made:

0.015 - 0.058 mm (0.0006 - 0.0023 in.)

NSK made:

0.015 - 0.056 mm (0.0006 - 0.0022 in.)

Maximum clearance:

KOYO made: 0.058 mm (0.0023 in.)

NSK made: 0.056 mm (0.0022 in.)

If the clearance exceeds the maximum, replace the gear, needle roller bearing or shaft.

3. REMOVE SNAP RING

Using 2 screwdrivers and a hammer, tap out the snap ring.

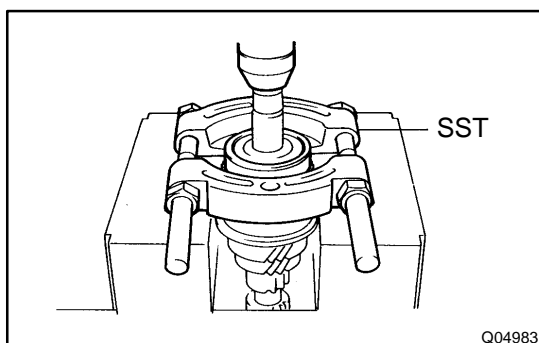

4. REMOVE REAR BALL BEARING, 4TH GEAR, NEEDLE ROLLER BEARING, SPACER AND SYNCHRONIZER RING FROM INPUT SHAFT

(a) Using SST and a press, remove the rear ball bearing and 4th gear.

SST 09950-00020

(b) Remove the needle roller bearings, spacer and synchronizer ring.

5. REMOVE SNAP RING

Using 2 screwdrivers and a hammer, tap out the snap ring.

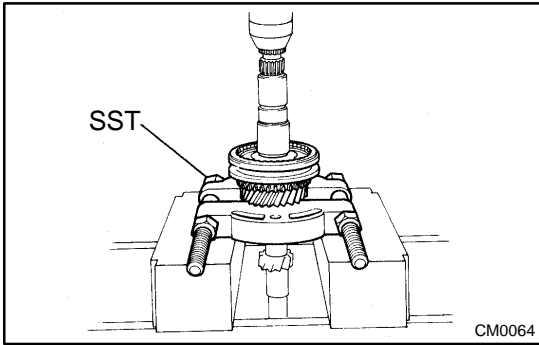

6. REMOVE NO. 2 HUB SLEEVE ASSEMBLY, 3RD GEAR, SYNCHRONIZER RING AND NEEDLE ROLLER BEARING

- (a) Using SST and a press, remove the No. 2 hub sleeve assembly, 3rd gear and synchronizer ring.
SST 09950-00020
- (b) Remove the needle roller bearings.

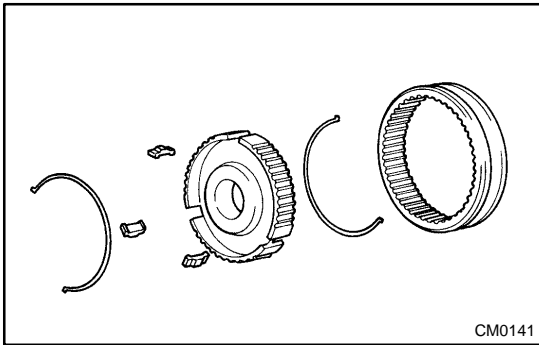

7. DISASSEMBLE NO. 2 HUB SLEEVE ASSEMBLY

- (a) Using a screwdriver, remove the 2 shifting key springs and 3 shifting keys from the No. 2 clutch hub.
- (b) Remove the No. 2 hub sleeve from the No. 2 clutch hub.