

INSPECTION

1. REMOVE VSV

- Disconnect the 2 EVAP hoses from the VSV.
- Disconnect the VSV connector.
- Disconnect the air flow meter connector and harness clamp from the cleaner cap.
- Remove the cleaner cap with VSV.

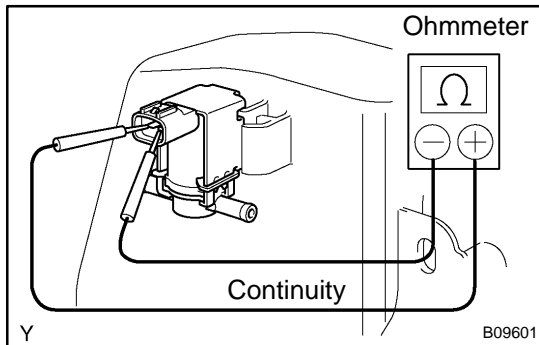

2. INSPECT VSV FOR OPEN CIRCUIT

Using an ohmmeter, check that there is continuity between the terminals.

Resistance:

27 - 33 Ω at 20°C (68°F)

If there is no continuity, replace the VSV.

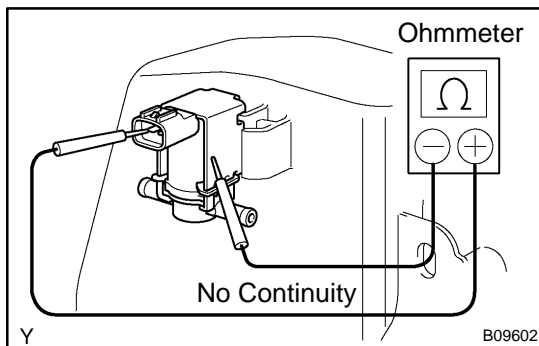

3. INSPECT VSV FOR GROUND

Using an ohmmeter, check that there is no continuity between each terminal and the body.

If there is continuity, replace the VSV.

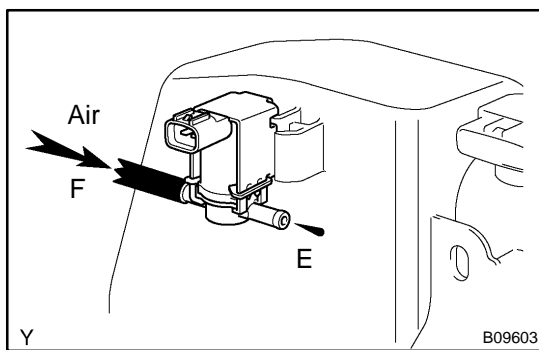

4. INSPECT VSV OPERATION

- Check that air flows with difficulty from port E to port F.

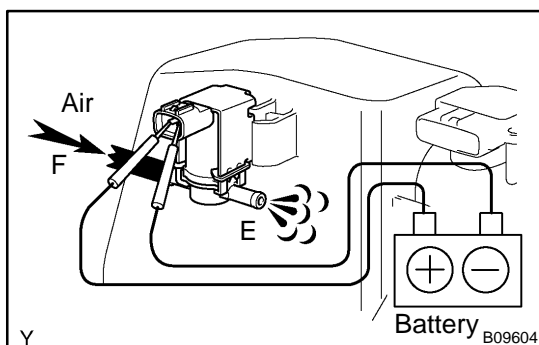

- Apply battery voltage across the terminals.

- Check that air flows from port E to port F.

If operation is not as specified, replace the VSV.

5. REINSTALL VSV

- Install the cleaner cap with the VSV.
- Connect the air flow meter connector and harness clamp.
- Connect the VSV connector.
- Connect the 2 EVAP hoses to the VSV.