



# **TOYOTA**

## **MAINTENANCE PROCEDURES**

**1986 MODELS**

**Land Cruiser**



## FOREWORD

This manual describes the maintenance procedures for the 1986 TOYOTA LAND CRUISER models sold in the United States and Canada.

Detailed repair procedures are contained in the following manuals:

- '81 2F Engine Emission Control Repair Manual (Pub. No. 36043E)
- 2F Engine Repair Manual (Pub. No. 36104E)
- B Series Engine Repair Manual (Pub. No. 36047E)
- 2H, 12H-T Engine Repair Manual (Pub. No. RM012E)
- Land Cruiser Heavy Duty Chassis and Body Repair Manual (Pub. No. 36262E)

For reference, the General Maintenance Items required of the vehicle owner/driver are listed in Appendix A.

All information in this manual is based on the latest product information at the time of publication. However, specifications and procedures are subject to change without notice.

**TOYOTA MOTOR CORPORATION**



# 1986 TOYOTA MAINTENANCE PROCEDURES MANUAL

INTRODUCTION	<b>1</b>
LAND CRUISER (2F ENGINE)	<b>2</b>
LAND CRUISER (3B,2H ENGINE)	<b>3</b>
APPENDIX	<b>A</b>



# INTRODUCTION

	Page
GENERAL PRECAUTIONS .....	1-2
PRECAUTIONS FOR VEHICLES EQUIPPED WITH A CATALYTIC CONVERTER .....	1-3
GENERAL REPAIR INSTRUCTIONS .....	1-4
ABBREVIATIONS USED IN THIS MANUAL .....	1-5

**1**



## GENERAL PRECAUTIONS

1. **Know the importance of periodic maintenance.**
  - (a) Every service item in the periodic maintenance list must be performed.
  - (b) Failing to item can cause the engine to run poorly and increase exhaust emissions.
2. **Listen to the customers comments carefully.**  
Always determine exactly what the customer complaint is, if any, and verify it before proceeding with repairs.
3. **Determine if you have an engine or emission system problem.**
  - (a) Engine problems are usually not caused by the emission control systems.
  - (b) When troubleshooting, always check the engine and the ignition system first.

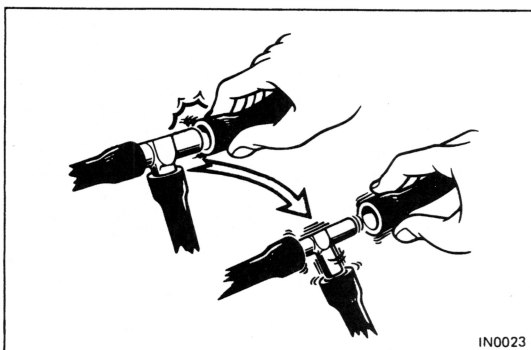
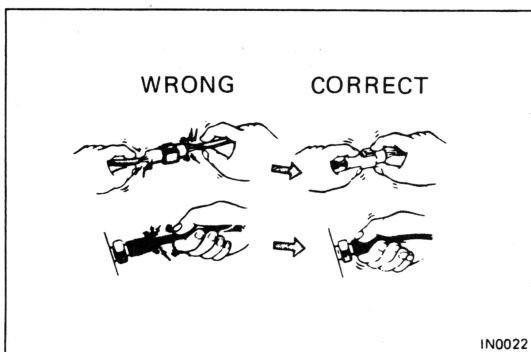
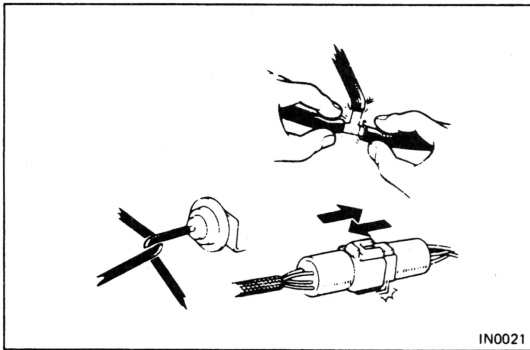

4. **Check hose and wiring connections first.**  
The most frequent cause of problems is simply a bad connection in wiring or vacuum hoses. Always make sure that connections are secure and correct.
5. **Observe the following precautions to avoid damage to the parts:**
  - (a) To disconnect vacuum hoses, pull on the end, not the middle of the hose.
  - (b) To pull apart electrical connectors, pull on the connector itself, not the wires.
  - (c) Be careful not to drop electrical components, such as sensors or relays. If they are dropped on a hard floor, they should be replaced and not reused.
  - (d) When steam cleaning an engine, protect the distributor, coil, air filter, carburetor intake, air pump and VCV from water.
  - (e) Never use an impact wrench to remove or install thermo switches or thermo sensors.
  - (f) When checking continuity at the wire connector, insert the tester probe carefully to prevent terminals from bending.
  - (g) When using a vacuum gauge, never force the hose onto a connector that is too large. Use a step-down adapter instead. Once the hose has been stretched, it may leak.



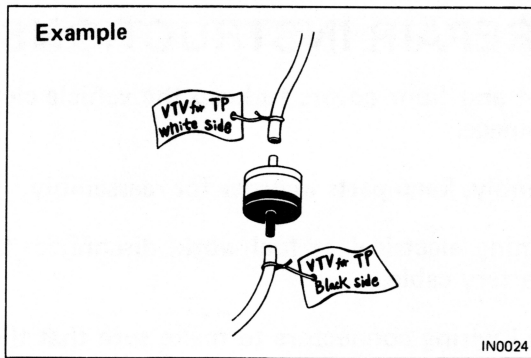

6. Tag hoses before disconnecting them:

- (a) When disconnecting vacuum hoses, use tags to identify how they should be reconnected.
- (b) After completing a job, double check that the vacuum hoses are properly connected. A label under the hood shows the proper layout.

## PRECAUTIONS FOR VEHICLES EQUIPPED WITH A CATALYTIC CONVERTER

**WARNING:** If large amounts of unburned gasoline flow into the catalytic converter, it may overheat and create a fire hazard. To prevent this, observe the following precautions and explain them to your customer.

1. Use only unleaded gasoline.
2. Avoid prolonged idling.  
Avoid running the engine at fast idle speed for more than 10 minutes and an idle speed for more than 20 minutes.
3. Avoid spark jump test.
  - (a) Spark jump only when absolutely necessary. Perform this test as rapidly as possible.
  - (b) While testing, never race the engine.
4. Avoid prolonged engine compression measurement.  
Engine compression tests must be made as rapidly as possible.
5. Do not run engine when fuel tank is nearly empty.  
This may cause the engine to misfire and create an extra load on the catalytic converter.
6. Avoid coasting with ignition turned off and prolonged braking.
7. Do not dispose of used catalytic converter near parts contaminated with gasoline or oil.



## GENERAL REPAIR INSTRUCTIONS

1. Use fender seat and floor covers to keep the vehicle clean and prevent damage.
2. During disassembly, keep parts in order for reassembly.
3. Before performing electrical or fuel work, disconnect the negative (–) battery cable.
4. Check hose and wiring connectors to make sure that they are secure and correct.
5. Always replace gaskets and O-rings with new ones.
6. Always use sealer on gaskets to prevent leaks.
7. Carefully observe all specifications for bolt torques. Always use a torque wrench.
8. Use of Special Service Tools (SST) may be required, depending on the nature of the repair. Be sure to use the SST where specified, and follow the proper work procedure.
9. Care must be taken when jacking up and supporting the vehicle. Be sure to lift and support the vehicle at the proper locations.
  - (a) If the vehicle is to be jacked up only at the front or rear end, be sure to block the wheels in order to ensure safety.
  - (b) Always use a hydraulic hoist or jack stand. It is extremely dangerous to work on a vehicle supported only by a jack, even for a small job that can be finished quickly.

## ABBREVIATIONS USED IN THIS MANUAL

A/C	Air Conditioner
A/T	Automatic Transmission
EGR	Exhaust Gas Recirculation
EX	Exhaust (manifold, valve)
IN	Intake (manifold, valve)
M/T	Manual Transmission
PCV	Positive Crankcase Ventilation
SST	Special Service Tools
T/M	Transmission
VCV	Vacuum Control Valve
w/	With
w/o	Without

# LAND CRUISER

## (2F ENGINE : FJ SERIES ONLY FOR USA)

	Page
MAINTENANCE SCHEDULE .....	2-2
MAINTENANCE OPERATIONS .....	2-4

### GENERAL NOTES:

- Every service item in the periodic maintenance list must be performed.
- Failure to do even one item can cause the engine to run poorly and increase exhaust emissions.



## MAINTENANCE SCHEDULE

Maintenance operations: A = Check and/or adjust if necessary  
 R = Replace, change or lubricate  
 I = Inspect and correct or replace if necessary

### NORMAL CONDITION SCHEDULE

System	Service interval (Odometer reading or months, whichever comes first)	Maintenance services beyond 60,000 miles (96,000 km) should be performed at the same intervals shown in each maintenance schedule.										See page (item No.)
		Miles × 1,000	10	15	20	30	40	45	50	60		
		Km × 1,000	16	24	32	48	64	72	80	96		
		Months	12	18	24	36	48	54	60	72		
ENGINE	Valve clearance			A		A		A		A	2-7 (item 11)	
	Drive belts <sup>(1)</sup>					I				I	2-4 (item 1)	
	Engine oil and oil filter		R		R	R	R		R	R	2-5 (item 3)	
	Engine coolant <sup>(2)</sup>									R	2-5 (item 4)	
	Exhaust pipes and mountings					I				I	2-6 (item 9)	
FUEL	Idle speed and fast idle speed <sup>(5)</sup>			A							2-7,8 (item 11,12)	
	Air filter					R				R	2-6 (item 8)	
	Fuel lines and connections					I				I	2-6 (item 6)	
	Fuel filler cap gasket									R	2-6 (item 5)	
IGNITION	Spark plugs *					R				R	2-4 (item 2)	
BRAKES	Brake linings and drums			I		I		I		I	2-10 (item 16)	
	Brake pads and discs			I		I		I		I	2-10 (item 17)	
	Brake line pipes and hoses			I		I		I		I	2-10 (item 15)	
CHASSIS	Steering linkage			I		I		I		I	2-12 (item 19)	
	Ball joints and dust covers			I		I		I		I	2-12 (item 19)	
	Manual transmission, transfer, differential and steering gear box oil <sup>(3)</sup>			I		I		I		I	2-9 (item 13) 2-9 (item 14)	
	Front wheel bearing grease					R				R	2-10 (item 18)	
	Steering knuckle and chassis grease <sup>(4)</sup>			R		R		R		R	2-13 (item 20)	
	Propeller shaft grease <sup>(4)</sup>			R		R		R		R	2-13 (item 20)	
	Bolts and nuts on chassis and body			I		I		I		I	2-13 (item 21)	

Maintenance service indicated by an asterisk (\*) is required under the terms of the Emission Control Systems Warranty. See Owner's Guide for complete warranty information.

#### NOTE:

- (1) After 60,000 miles (96,000 km) or 72 months, inspect every 10,000 miles (16,000 km) or 12 months.
- (2) After 60,000 miles (96,000 km) or 72 months, replace every 30,000 miles (48,000 km) or 36 months.
- (3) Inspect the steering gear box only for oil leakage.
- (4) If the vehicle has been immersed in water, it should be re-greased within 24 hours.
- (5) Adjustment at 15,000 miles (24,000 km) or 18 months only.

Follow the severe condition schedule if vehicle is operated mainly under one or more of the following severe conditions:

- Towing a trailer, using a camper or car top carrier.
- Operating on dusty, rough, muddy or salt spread roads.
- Repeat short trips less than 5 miles (8 km) and outside temperatures remain below freezing.
- Extensive idling such as police, taxi or door-to-door delivery use.

**SEVERE CONDITION SCHEDULE**

System	Service interval (Odometer reading or months, whichever comes first)	Maintenance services beyond 60,000 miles (96,000 km) should be performed at the same intervals shown in each maintenance schedule.																	See page (item No.)	
		Miles × 1,000	5	7.5	10	15	20	22.5	25	30	35	37.5	40	45	50	52.5	55	60		
	Km × 1,000	8	12	16	24	32	36	40	48	56	60	64	72	80	84	88	96			
	Months	6	9	12	18	24	27	30	36	42	45	48	54	60	63	66	72			
ENGINE	Valve clearance					A								A					A	2-7 (item 10)
	Drive belts <sup>(1)</sup>									I									I	2-4 (item 1)
	Engine oil and oil filter	R			R	R	R			R	R	R		R	R	R		R	R	2-5 (item 3)
	Engine coolant <sup>(2)</sup>																		R	2-5 (item 4)
	Exhaust pipes and mountings					I					I				I				I	2-6 (item 9)
FUEL	Idle speed and fast idle speed <sup>(6)</sup>					A														2-7,8 (item 11,12)
	Air filter <sup>(5)</sup>	I			I	I	I			I	R	I		I	I	I		I	R	2-6 (item 7,8)
	Fuel lines and connections										I								I	2-6 (item 6)
	Fuel filler cap gasket																		R	2-6 (item 5)
IGNITION	Spark plugs *																	R	2-4 (item 2)	
BRAKES	Brake linings and drums			I		I			I			I		I			I		I	2-10 (item 16)
	Brake pads and discs			I		I			I			I		I			I		I	2-10 (item 17)
	Brake line pipes and hoses					I					I				I				I	2-10 (item 15)
CHASSIS	Steering linkage			I		I			I			I		I			I		I	2-12 (item 19)
	Ball joints and dust covers			I		I			I			I		I			I		I	2-12 (item 19)
	Manual transmission, transfer, differential and steering gear box oil <sup>(3)</sup>						R												R	2-9 (item 13) 2-9 (item 14)
	Front wheel bearing grease										R								R	2-10 (item 18)
	Steering knuckle and chassis grease <sup>(4)</sup>			R		R			R			R			R			R	R	2-13 (item 20)
	Propeller shaft grease <sup>(4)</sup>			R		R			R			R			R			R	R	2-13 (item 20)
	Bolts and nuts on chassis and body			I		I			I			I			I			I	I	2-13 (item 21)

Maintenance service indicated by an asterisk (\*) is required under the terms of the Emission Control Systems Warranty. See Owner's Guide for complete warranty information.

**NOTE:**

- (1) After 60,000 miles (96,000 km) or 72 months, inspect every 10,000 miles (16,000 km) or 12 months.
- (2) After 60,000 miles (96,000 km) or 72 months, replace every 30,000 miles (48,000 km) or 36 months.
- (3) Inspect the steering gear box only for oil leakage.
- (4) If the vehicle has been immersed in water, it should be re-greased within 24 hours.
- (5) Applicable when operating mainly on dusty roads. If not, follow the normal condition schedule.
- (6) Adjustment at 15,000 miles (24,000 km) or 18 months only.

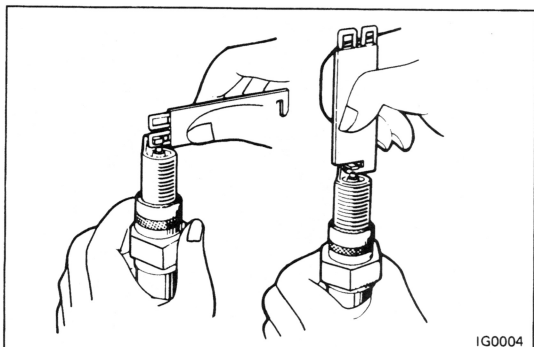
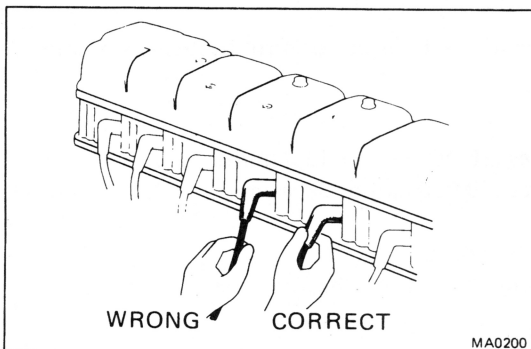
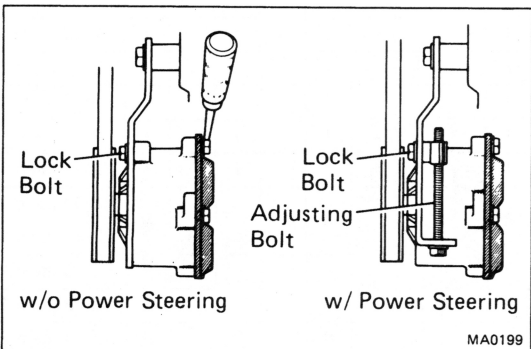
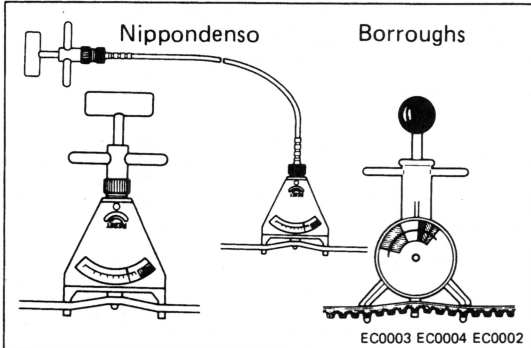
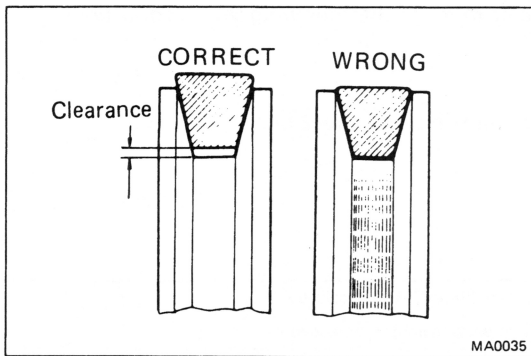

## MAINTENANCE OPERATIONS

### ENGINE

#### Cold Engine Operations

##### 1. INSPECT DRIVE BELTS

- (a) Visually check the drive belt for cracks, oiliness or wear. Check that the belt does not touch the bottom of the pulley groove.

If necessary, replace the drive belt.

- (b) Using a belt tension gauge, check the drive belt tension.

Belt tension gauge:

Nippondenso	BTG-20 (95506-00020)
Borroughs	No. BT-33-73F

Drive belt tension:

Used belt	Air con.	80 ± 20 lb
	Others	100 ± 20 lb
New belt	Air con.	125 ± 25 lb
	Others	145 ± 25 lb

If necessary, adjust the drive belt tension.

#### CAUTION:

- Do not pry on the die-cast body of the air pump.
- If the vehicle is equipped with power steering, the belt tension of the air pump and alternator is adjusted by turning the adjusting bolt.

#### NOTE:

- "New belt" refers to a belt which has been used less than 5 minutes on a running engine.
- "Used belt" refers to a belt which has been used on a running engine for 5 minutes or more.
- After replacing the drive belt, check that it fits properly in the ribbed grooves, especially in the places difficult to see.

##### 2. REPLACE SPARK PLUGS

- (a) Disconnect the spark plug wires at the boot. **DO NOT** pull on the wires. Remove the spark plugs.

- (b) Set the gap on the new plugs.

Gap: 0.8 mm (0.031 in.)

Recommended spark plugs:

ND	W14EXR-U
NGK	BPR4EY



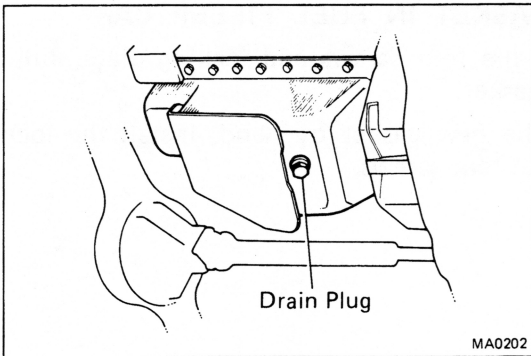

**3. REPLACE ENGINE OIL AND OIL FILTER**

- (a) Remove the oil drain plug and drain the oil into a container.

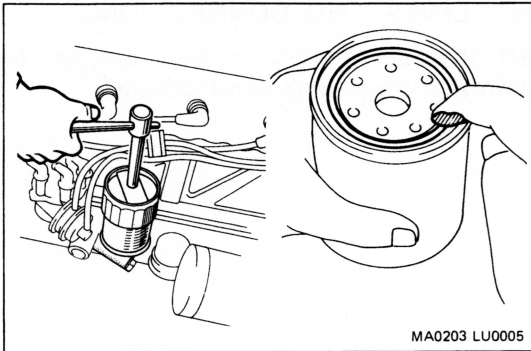

- (b) Using SST, remove the oil filter (located on right side of engine block).

SST 09228-44011

- (c) Inspect and clean the oil filter installation surface.
- (d) Apply clean engine oil to the gasket of the new oil filter.

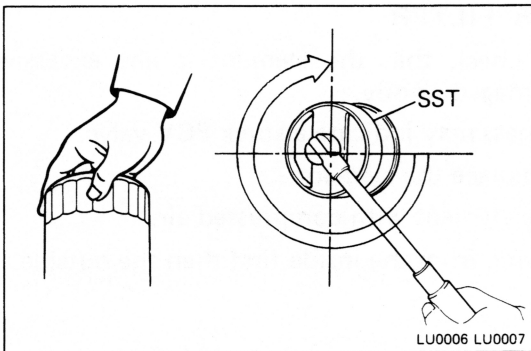

- (e) Lightly screw in the oil filter to where you feel resistance.

- (f) Then, using SST, tighten the oil filter an extra 3/4 turn.

SST 09228-44011

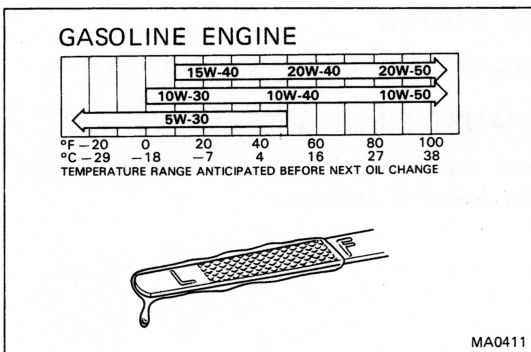

- (g) Clean and install the oil drain plug with a new gasket.
- (h) Fill the engine with new oil. Use API grade SF or SF/CC, multigrade viscosity and fuel-efficient oil.

**Engine oil capacity (Drain and refill with oil filter change):**  
 7.8 liters (8.2 US qts, 6.9 Imp. qts)

**4. REPLACE ENGINE COOLANT**

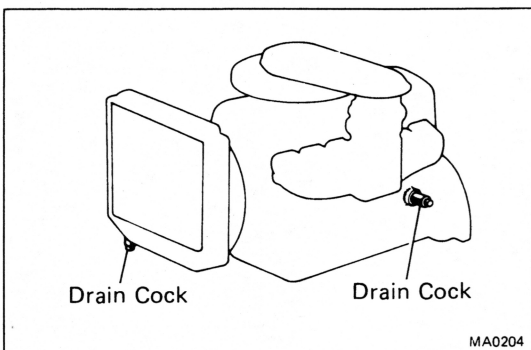

- (a) Drain the coolant from the radiator and engine drain cocks. (Engine drain is at left rear of engine block.)
- (b) Close the drain cocks.
- (c) Fill system with coolant.

**Coolant capacity (w/ heater or air conditioner):**  
 16.5 liters (17.4 US qts, 14.5 Imp. qts)

Use a good brand of ethylene-glycol base coolant, mixed according to the manufacturer's instructions.

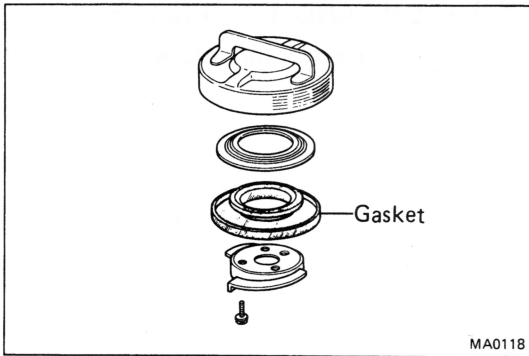

### 5. REPLACE GASKET IN FUEL FILLER CAP

- (a) Remove the four screws and locking plate. Pull out the old gasket.
- (b) Install the new gasket by hand. Install the locking plate with four screws.

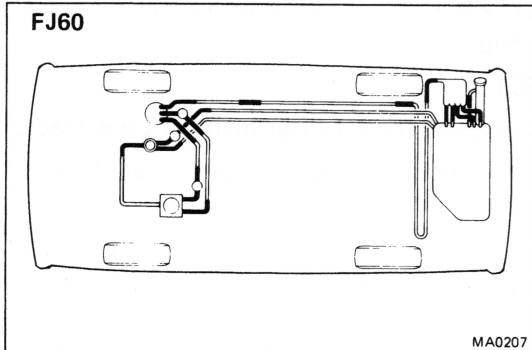

### 6. INSPECT FUEL LINES AND CONNECTIONS

Visually inspect the fuel lines for cracks, leakage, loose connections, deformation or tank band looseness.

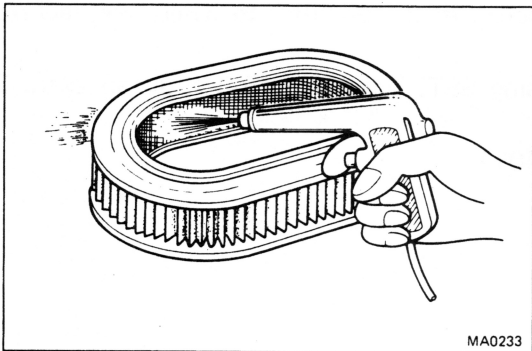

### 7. INSPECT AIR FILTER

- (a) Visually check that the element is not excessively dirty, damaged or oily.

NOTE: Oiliness may indicate a stuck PCV valve.

If necessary, replace the element.

- (b) Clean the element with compressed air.

Clean by blowing from the inside first then the outside.

### 8. REPLACE AIR FILTER

Replace the used air cleaner element with a new one.

### 9. INSPECT EXHAUST PIPES AND MOUNTINGS

Visually inspect the pipes, hangers, and connections for severe corrosion, leaks or damage.

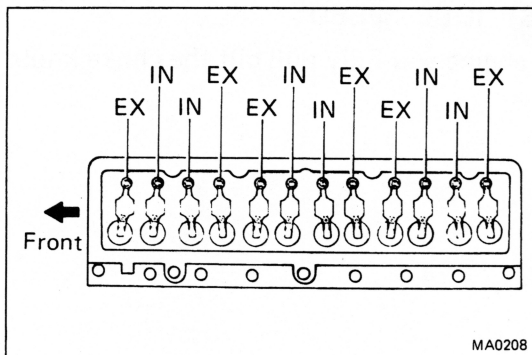

## Hot Engine Operations

### 10. ADJUST VALVE CLEARANCE

- (a) Warm up the engine to normal operating temperature.
- (b) Stop the engine and remove the valve cover.
- (c) Adjust the valve clearance.
  - Start the engine.
  - Use a feeler gauge to measure between the valve stem and rocker arm. Loosen the lock nut and turn the adjusting screw to set the proper clearance. Hold the adjusting screw in position and tighten the lock nut.
  - Recheck the clearance. The feeler gauge should move with a very slight drag.

Valve clearance: Intake 0.20 mm (0.008 in.)  
 Exhaust 0.35 mm (0.014 in.)

- (d) Reinstall the valve cover.
- (e) Reinstall the air cleaner.

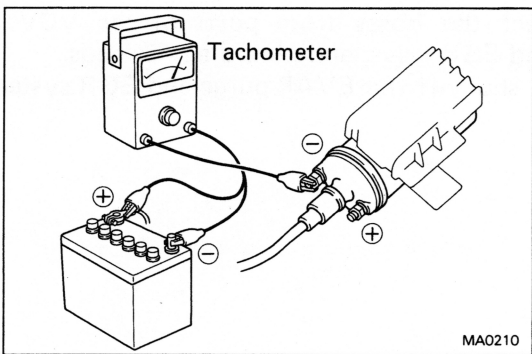
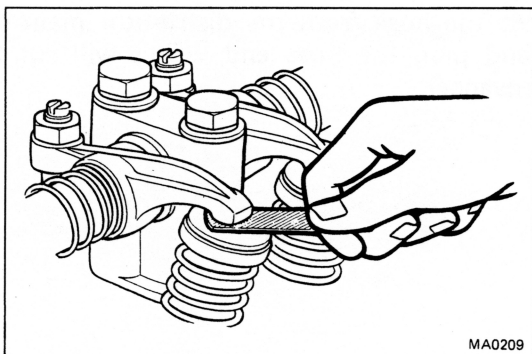

### 11. ADJUST IDLE SPEED

- (a) Preparation
  - Air cleaner installed
  - Choke valve fully open
  - Accessories switched off
  - All vacuum lines connected (i.e., AI, EGR systems, etc.)
  - Transmission in NEUTRAL position
  - Engine idling at normal operating temperature
- (b) Connect a tachometer to the engine. Connect the tachometer positive (+) terminal to the ignition coil negative (-) terminal.

#### CAUTION:

1. NEVER allow the tachometer terminal to touch ground as it could result in damage to the igniter and/or ignition coil.
2. As some tachometers will damage the ignition, we recommend checking the compatibility of your unit before using.
- (c) Set the idle speed by turning the IDLE SPEED ADJUSTING SCREW.

Idle speed: 650 rpm

NOTE: Leave the tachometer connected for further adjustments.

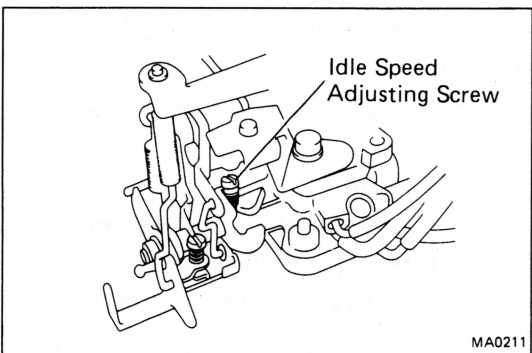



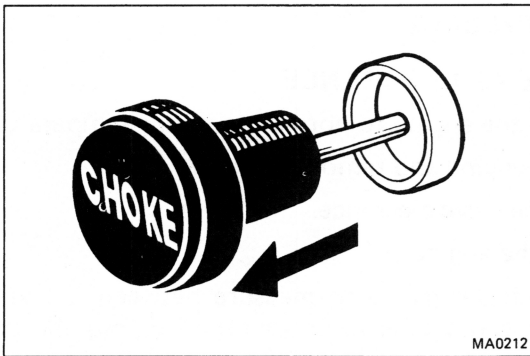

## 12. ADJUST FAST IDLE SPEED

- (a) Stop the engine and fully pull out the choke knob.

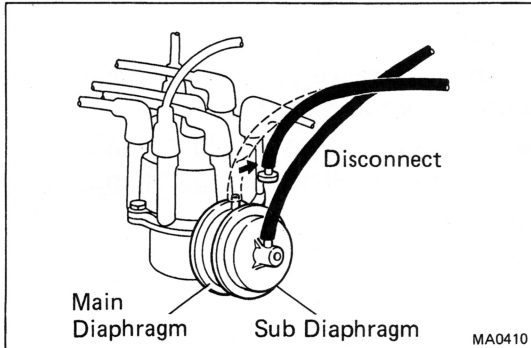

- (b) Disconnect the hose from the distributor main diaphragm and plug the hose end. This will cut the vacuum advancer.

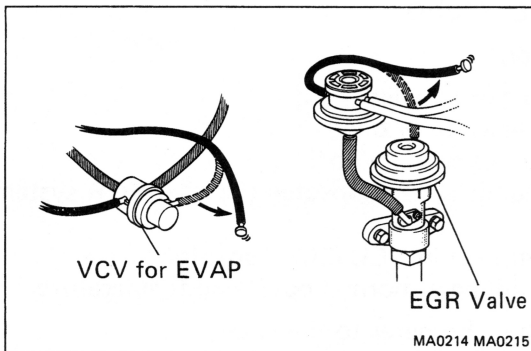

- (c) Disconnect the hoses from ports of the VCV for EVAP and EGR valve, and plug the hose ends. This will shut off the EVAP purge and EGR systems.

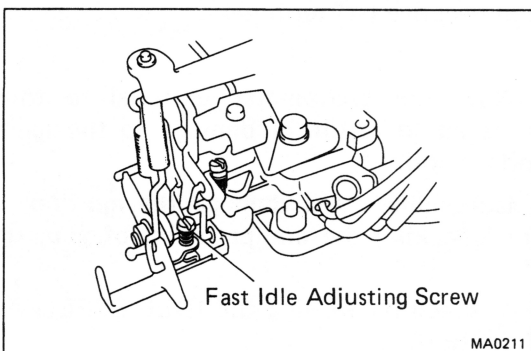

- (d) Fully open the choke valve.
- (e) Start the engine.
- (f) Set the fast idle speed by turning the fast idle adjusting screw.

**Fast idle speed: 1,800 rpm**

- (g) Check that the engine returns to idle speed when the choke button is pushed in all the way.
- (h) Reconnect the hoses to the proper locations.

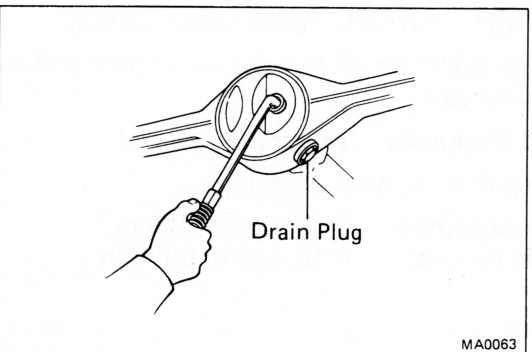
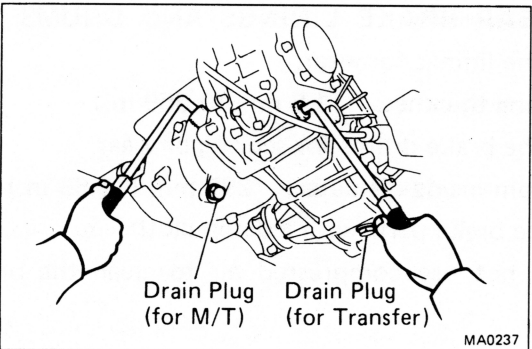
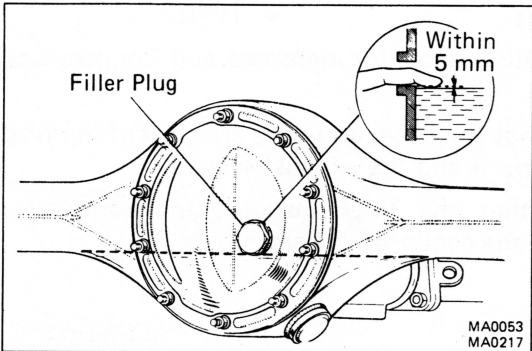
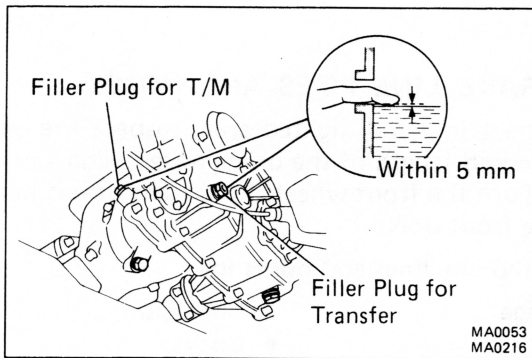

## TRANSMISSION

### 13. CHECK OIL LEVEL IN TRANSMISSION, TRANSFER AND DIFFERENTIAL

Remove the filler plug and feel inside the hole with your finger. Check that the oil comes to within 5 mm (0.20 in.) of the bottom edge of the hole. If the level is low, add oil until it begins to run out of the filler hole.

Transmission and transfer oil –

Oil grade: API GL-4 or GL-5

Viscosity: SAE 90

Differential oil –

Oil grade: API GL-5 hypoid gear oil

Viscosity: Above  $-18^{\circ}\text{C}$  ( $0^{\circ}\text{F}$ ) SAE 90

Below  $-18^{\circ}\text{C}$  ( $0^{\circ}\text{F}$ ) SAE 80W-90  
or 80W

### 14. REPLACE TRANSMISSION, TRANSFER AND DIFFERENTIAL OIL

- Remove the drain plug and drain the oil.
- Reinstall the drain plug.
- Add new oil until it begins to run out of the filler hole.

Transmission and transfer oil –

Capacity:

Transmission 3.5 liters  
(3.7 US qts, 3.1 Imp. qts)

Transfer 2.2 liters  
(2.3 US qts, 1.9 Imp. qts)

Differential oil –

Capacity:

Front 3.0 liters  
(3.2 US qts, 2.6 Imp. qts)

Rear 2.5 liters  
(2.6 US qts, 2.2 Imp. qts)

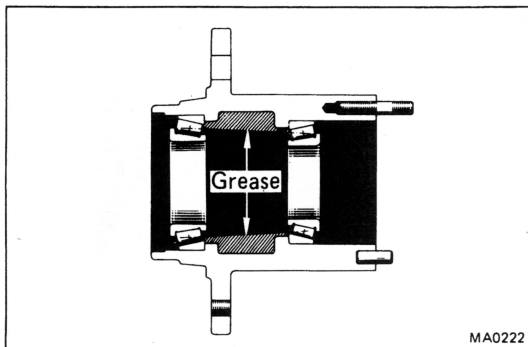
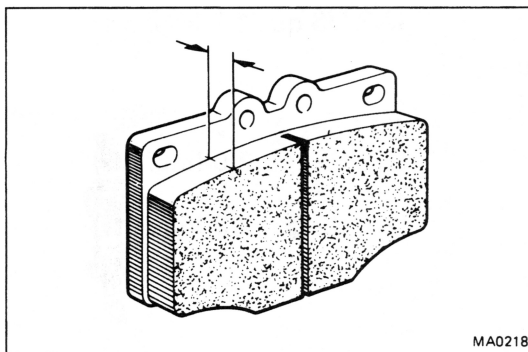
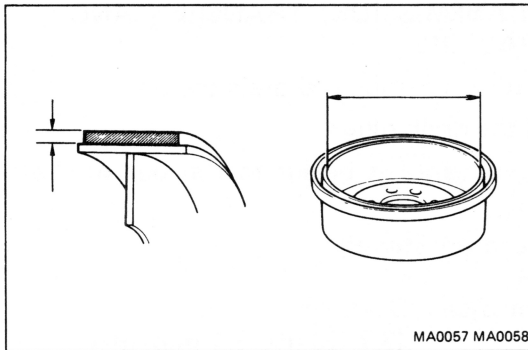
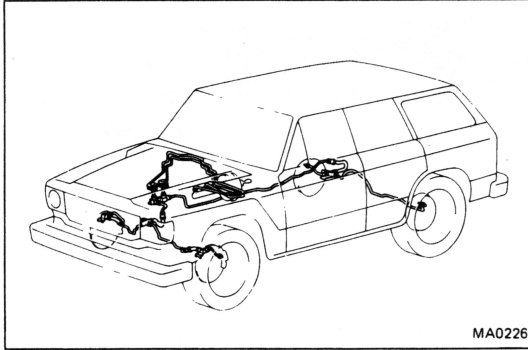
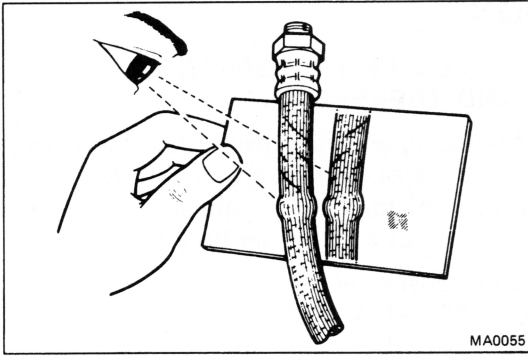

## BRAKES

### 15. INSPECT BRAKE LINE PIPES AND HOSES

**NOTE:** Inspect in a well lighted area. Inspect the entire circumference and length of the brake hoses using a mirror as required. Turn the front wheels fully right or left before inspecting the front brake.

- (a) Check all brake lines and hoses for:
- Damage
  - Wear
  - Deformation
  - Cracks
  - Corrosion
  - Leaks
  - Bends
  - Twists
- (b) Check all clamps for tightness and connections for leakage.
- (c) Check that the hoses and lines are clear of sharp edges, moving parts and the exhaust system.
- (d) Check that the lines installed in grommets pass through the center of the grommets.

### 16. INSPECT REAR BRAKE LININGS AND DRUMS

- (a) Check the linings for wear.

**Minimum lining thickness: 1.5 mm (0.059 in.)**

- (b) Check the brake drums for scoring or wear.

**Maximum drum inside diameter: 297 mm (11.69 in.)**

- (c) Clean the brake parts with a damp cloth.

**NOTE:** Do not use compressed air to clean the brake parts.

### 17. INSPECT FRONT BRAKE PADS AND DISCS

- (a) Check the thickness of the disc brake pads and check for irregular wear.

**Minimum pad thickness: 1.0 mm (0.039 in.)**

- (b) Check the disc for wear or runout.

**Minimum disc thickness: 19.0 mm (0.748 in.)**

**Maximum disc runout: 0.15 mm (0.0059 in.)**

## CHASSIS

### 18. REPACK FRONT WHEEL BEARINGS

- (a) Change the front wheel bearing grease.
- Remove the hubs and inner and outer bearings. Clean in solvent and inspect the bearings for damage.
  - Pack the bearings and axle hubs with lithium base multipurpose grease.

**Grease grade: Lithium base multipurpose grease (NLGI No. 2)**



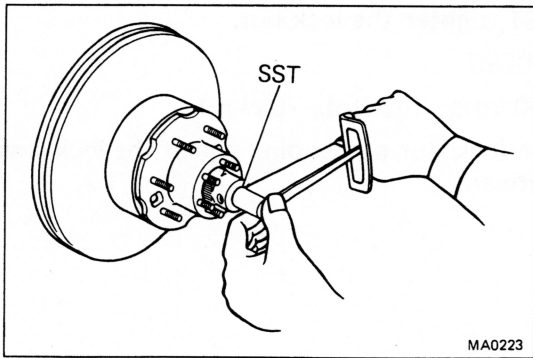

- (b) Install the hubs and adjust the wheel bearing preload.
- Using SST, tighten the adjusting nut and turn the hub right and left two or three times.

SST 09607-60020

Torque: 600 kg-cm (43 ft-lb, 59 N·m)

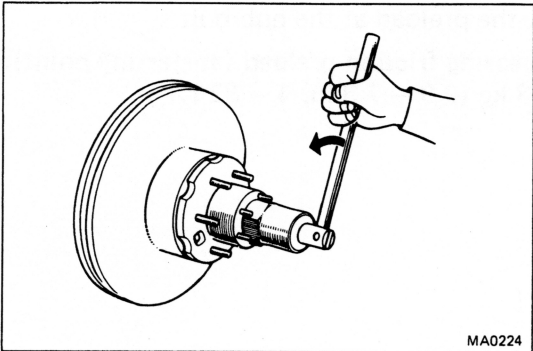

- Loosen the adjusting nut until it can be turned by hand.

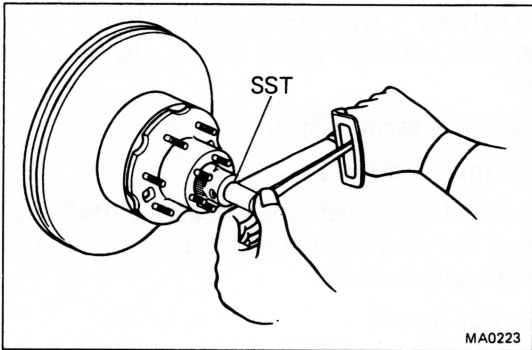

- Retighten the adjusting nut.

Torque: 40 – 70 kg-cm (35 – 60 in.-lb, 4.0 – 6.8 N·m)

- Insure that the hub turns smoothly and there is no play in the bearing.

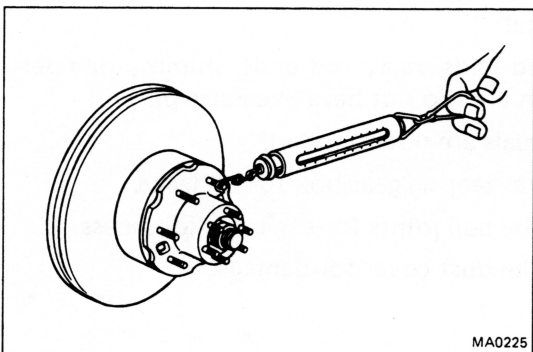

- Using a spring tension gauge, check for correct preload.

Front wheel bearing friction preload (at starting point):  
0.4 – 3.3 kg (0.9 – 7.3 lb, 4 – 32 N)

If the preload is incorrect, loosen or tighten the nut to correct the preload.

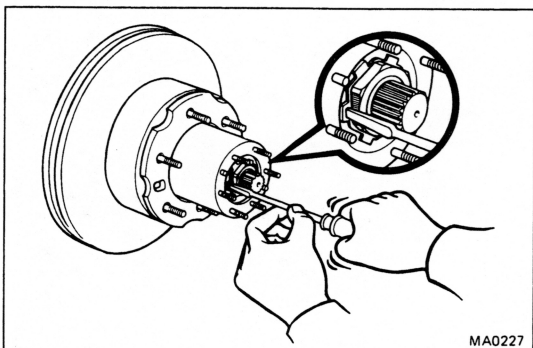

- (c) Install the lock washer and lock nut.
- (d) Lock the adjusting nut by bending one of the lock washer teeth inward.

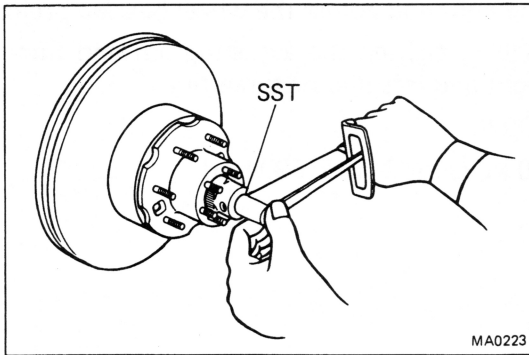

(e) Using SST, tighten the lock nut.

SST 09607-60020

**Torque: 800 kg-cm (58 ft-lb, 78 N·m)**

(f) Lock the lock nut by bending one of the lock washer teeth outward.

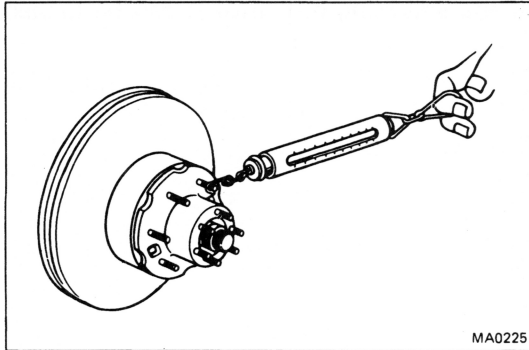

(g) Recheck the preload at the hub bolt.

**Front wheel bearing friction preload (at starting point):**  
**0.4 – 3.3 kg (0.9 – 7.3 lb, 4 – 32 N)**

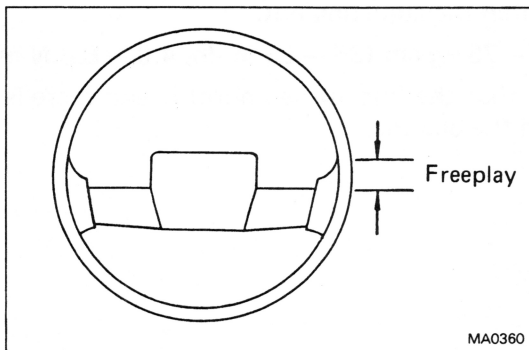

#### 19. INSPECT STEERING LINKAGE, GEAR BOX, STEERING WHEEL FREEPLAY, BALL JOINTS AND DUST COVER

(a) Check that the steering wheel freeplay is:

**Maximum: 40 mm (1.57 in.)**

With the vehicle stopped and wheels pointed straight ahead, rock the steering wheel gently back and forth with light finger pressure.

If correct, adjust or repair.

(b) Check the steering linkage for looseness or damage.

Check that:

- Tie rod ends, relay rod ends, shimmy damper and pitman arm do not have excessive play.
- Dust seals are not damaged.

(c) Check the steering gear box for oil leaks.

(d) Inspect the ball joints for excessive looseness.

(e) Inspect the dust cover for damage.

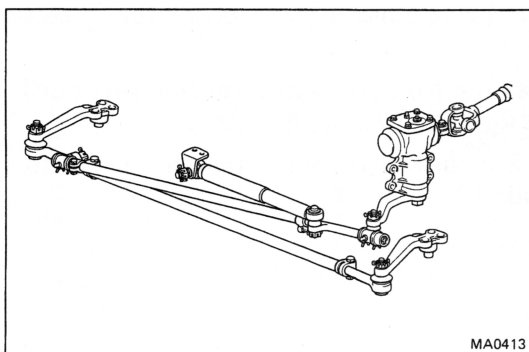

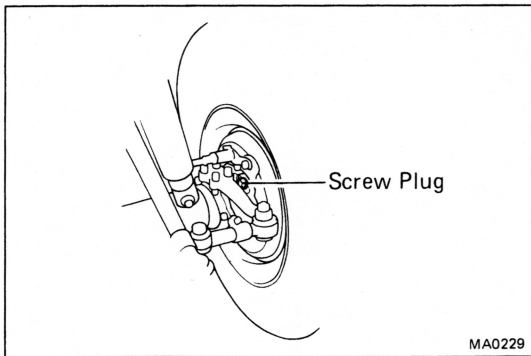

MA0229

**20. LUBE STEERING KNUCKLE, CHASSIS AND PROPELLER SHAFT**

- (a) Remove the screw plug from each steering knuckle and repack with lubricant.

**Steering knuckle grease –**

**Molybdenum disulfide lithium base chassis grease (NLGI No. 2)**

- (b) Reinstall the two screw plugs.
- (c) Lubricate chassis components, referring to the lubrication chart. Before pumping in grease, wipe off any mud and dust on the grease fitting.

**Grease grade:**

**Steering link ends –**

**Molybdenum disulfide lithium base chassis grease (NLGI No. 2)**

**Propeller shaft –**

**Lithium base chassis grease (NLGI No. 2)**

- (d) Check the steering linkage dust seals for damage.

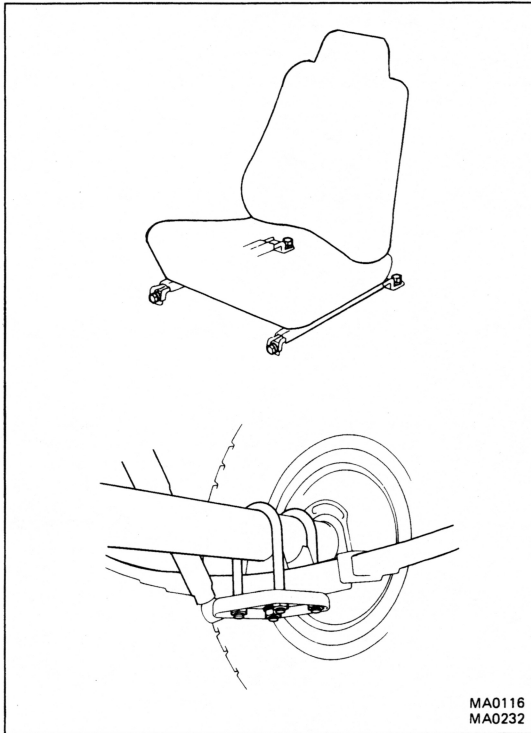

MA0116  
MA0232

**21. TIGHTEN BOLTS AND NUTS ON CHASSIS AND BODY**

Tighten the following parts:

- Front seats mounting bolts

**Torque: 375 kg-cm (27 ft-lb, 37 N·m)**

- Front and rear leaf spring U-bolt mounting nuts

**Torque: 1,250 kg-cm (90 ft-lb, 123 N·m)**

**FJ 60 Series**

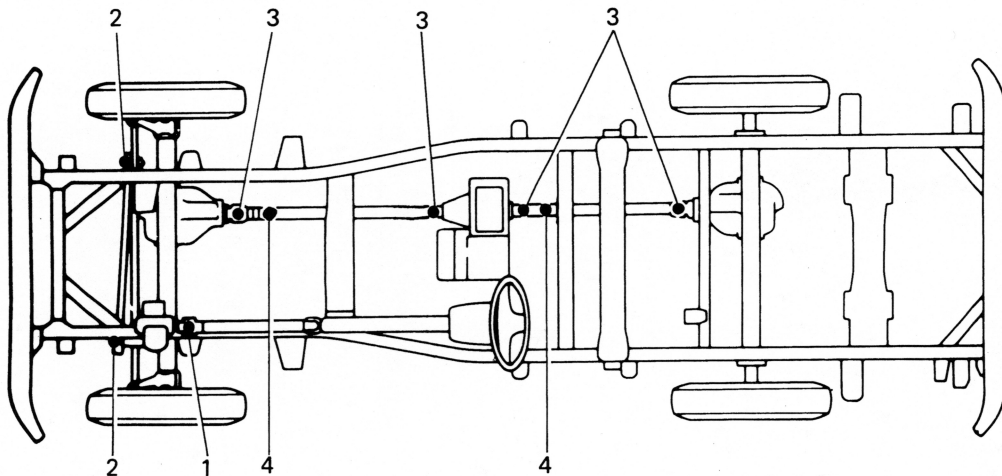

**Lubricating Positions:**

**Steering**

- 1. Slide Yoke
- 2. Relay Rod End

**Propeller Shaft**

- 3. Spider
- 4. Slide Yoke

MA0230

# LAND CRUISER

## (3B,2H ENGINE : BJ,HJ SERIES ONLY FOR CANADA)

	Page
MAINTENANCE SCHEDULE .....	3-2
MAINTENANCE OPERATIONS .....	3-4

**GENERAL NOTES:**

- Every service item in the periodic maintenance list must be performed.
- Failure to do even one item can cause the engine to run poorly and increase exhaust emissions.



## MAINTENANCE SCHEDULE

Maintenance operations: A = Check and/or adjust if necessary;  
 R = Replace, change or lubricate;  
 I = Inspect and correct or replace if necessary

### NORMAL CONDITION SCHEDULE

System	Service interval (Odometer reading or months, whichever comes first)	Maintenance services beyond 96,000 km should be performed at the same intervals shown in each maintenance schedule.										See page (item No.)	
		Maintenance items	Km × 1,000	16	24	32	48	64	72	80	96		
			Months	12	18	24	36	48	54	60	72		
ENGINE	Valve clearance			A			A			A		A	3-8 (item 16)
	Drive belts			I			R			I		R	3-4 (item 1,2)
	Engine oil and oil filter						R(1)					3-5 (item 5,6)	
	Engine coolant <sup>(2)</sup>											R	3-6 (item 7)
	Vacuum pump oil hoses						I					R	3-4,5 (item 3,4)
	Exhaust pipes and mountings						I					I	3-7 (item 12)
FUEL	Idle speed <sup>(5)</sup>			A			A						3-9 (item 17)
	Air filter			I			R			I		R	3-6 (item 8,9)
	Fuel filter						R					R	3-7 (item 14)
	Fuel feed pump filter						I					I	3-7 (item 13)
	Injection pump governor diaphragm oil						R			R		R	3-8 (item 15)
	Fuel lines and connections						I					I	3-7 (item 11)
	Fuel filler cap gasket											R	3-6 (item 10)
BRAKES	Brake linings and drums			I			I			I		I	3-11 (item 23)
	Brake pads and discs			I			I			I		I	3-12 (item 24)
	Brake line pipes and hoses			I			I			I		I	3-11 (item 22)
CHASSIS	Steering linkage			I			I			I		I	3-14 (item 26)
	Ball joints and dust covers			I			I			I		I	3-14 (item 26)
	Transmission, transfer, differential and steering gear box oil <sup>(3)</sup>			I			I			I		I	3-9 (item 18) 3-10 (item 19)
	Front wheel bearing grease						R					R	3-12 (item 25)
	Steering knuckle and chassis grease <sup>(4)</sup>			R			R			R		R	3-14 (item 27)
	Propeller shaft grease <sup>(4)</sup>			R			R			R		R	3-14 (item 27)
	Bolts and nuts on chassis and body			I			I			I		I	3-16 (item 28)

**NOTE:**

- (1) Replace every 6,000 km or 6 months, but replace oil filter every 12,000 km or 12 months.
- (2) After 96,000 km or 72 months, replace every 48,000 km or 36 months.
- (3) Inspect the steering gear box only for oil leakage.
- (4) If the vehicle has been immersed in water, it should be re-greased within 24 hours.
- (5) Adjust only at the first 24,000 km or 18 months and 48,000 km or 36 months.

Follow the severe condition schedule if vehicle is operated mainly under one or more of the following severe conditions:

- Towing a trailer, using a camper or car top carrier.
- Operating on dusty, rough, muddy or salt spread roads.
- Repeat short trips less than 5 miles (8 km) and outside temperatures remain below freezing.
- Extensive idling such as police, taxi or door-to-door delivery use.

### SEVERE CONDITION SCHEDULE

System	Service interval (Odometer reading or months, whichever comes first)	Maintenance services beyond 96,000 km should be performed at the same intervals shown in each maintenance schedule.																See page (item No.)		
		Km × 1,000	8	12	16	24	32	36	40	48	56	60	64	72	80	84	88		96	
		Months	6	9	12	18	24	27	30	36	42	45	48	54	60	63	66		72	
ENGINE	Valve clearance					A								A					A	3-8 (item 16)
	Drive belts					I					R								R	3-4 (item 1,2)
	Engine oil and oil filter																		R(1)	3-5 (item 5,6)
	Engine coolant <sup>(2)</sup>																		R	3-6 (item 7)
	Vacuum pump oil hoses										I								R	3-4, 5 (item 3, 4)
	Exhaust pipes and mountings						I					I				I			I	3-7 (item 12)
FUEL	Idle speed <sup>(7)</sup>					A													A	3-9 (item 17)
	Air filter <sup>(3)</sup>																		(4)	3-6 (item 8,9)
	Fuel filter										R								R	3-7 (item 14)
	Fuel feed pump filter										I								I	3-7 (item 13)
	Injection pump governor diaphragm oil						R												R	3-8 (item 15)
	Fuel lines and connections											I							I	3-7 (item 11)
	Fuel filler cap gasket																		R	3-6 (item 10)
BRAKES	Brake linings and drums			I		I		I		I		I		I		I		I	3-11 (item 23)	
	Brake pads and discs			I		I		I		I		I		I		I		I	3-12 (item 24)	
	Brake line pipes and hoses					I					I							I	3-11 (item 22)	
CHASSIS	Steering linkage			I		I		I		I		I		I		I		I	3-14 (item 26)	
	Ball joints and dust covers			I		I		I		I		I		I		I		I	3-14 (item 26)	
	Transmission, transfer, differential and steering gear box oil <sup>(5)</sup>						R											R	3-10 (item 20) 3-10 (item 21)	
	Front wheel bearing grease										R							R	3-12 (item 25)	
	Steering knuckle and chassis grease <sup>(6)</sup>				R		R		R			R		R		R		R	3-14 (item 27)	
	Propeller shaft grease <sup>(6)</sup>				R		R		R			R		R		R		R	3-14 (item 27)	
	Bolts and nuts on chassis and body				I		I		I		I		I		I		I		I	3-16 (item 28)

NOTE:

- (1) Replace every 3,000 km or 3 months, but replace oil filter every 6,000 km or 6 months.
- (2) After 96,000 km or 72 months, replace every 48,000 km or 36 months.
- (3) Applicable when operating mainly on dusty roads. If not, follow the normal condition schedule.
- (4) Replace every 48,000 km or 36 months, inspect every 6,000 km or 6 months.
- (5) Inspect the steering gear box only for oil leakage.
- (6) If the vehicle has been immersed in water, it should be re-greased within 24 hours.
- (7) Adjust only at the first 24,000 km or 18 months and 48,000 km or 36 months.

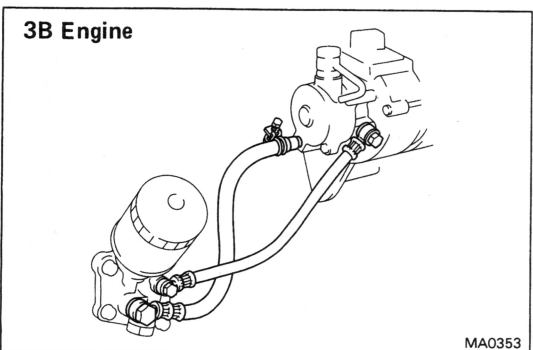
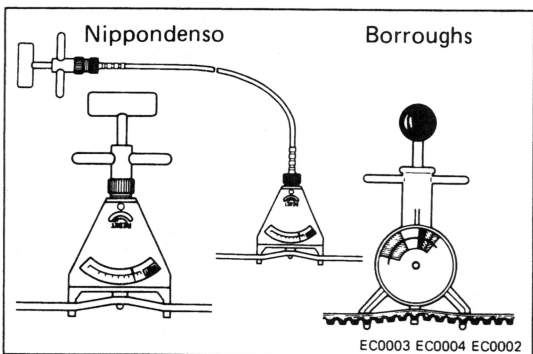
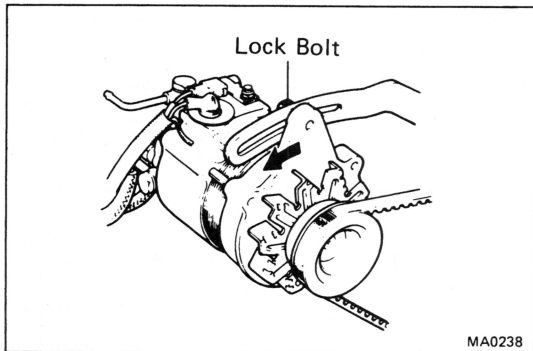
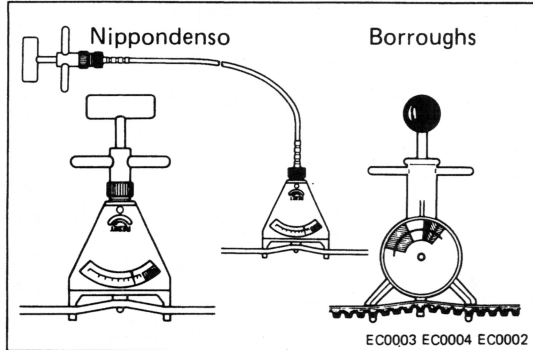
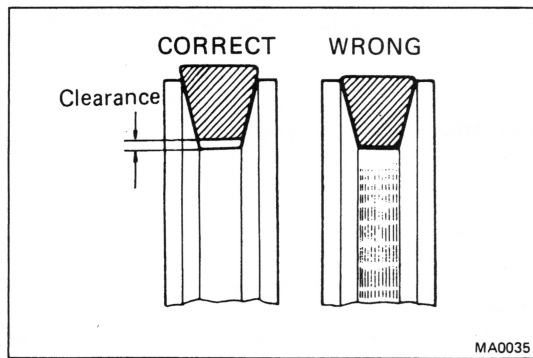

## MAINTENANCE OPERATIONS

### ENGINE

#### Cold Engine Operations

##### 1. INSPECT DRIVE BELTS

- Visually check the drive belts for cracks, oiliness or wear. Check that the belt does not touch the bottom of the pulley groove.

If necessary, replace the drive belt.

- Using a belt tension gauge, check the drive belt tension.

Belt tension gauge:

Nippondenso BTG-20 (95506-00020)

Borroughs No. BT-33-73F

NOTE: When checking the tension, be sure the gauge is on the belt protrusions.

Drive belt tension: Air Con.  $80 \pm 20$  lb  
(Used belt) Others  $100 \pm 20$  lb

If necessary, adjust the drive belt tension.

##### 2. REPLACE DRIVE BELTS

- Remove the old belts.
- Install a new belt and adjust it to the specified tension.
- Using a belt tension gauge, check the drive belt tension.

Belt tension gauge:

Nippondenso BTG-20 (95506-00020)

Borroughs No. BT-33-73F

Drive belt tension: Air Con.  $125 \pm 25$  lb  
(New belt) Others  $145 \pm 25$  lb

NOTE:

- When checking the tension, be sure the gauge is on the belt protrusions.
- "New belt" refers to a belt which has been used less than 5 minutes on a running engine.
- "Used belt" refers to a belt which has been used on a running engine for 5 minutes or more.
- After replacing the drive belt, check that it fits properly in the ribbed grooves, especially in the places difficult to see.

##### 3. INSPECT VACUUM PUMP OIL HOSES

- Visually check for oil leakage.
- Check the hoses for loose or bad connections.
- Check the hoses for damage or cracks.

Squeeze the hoses to check for internal breakdown.

If soft, replace.

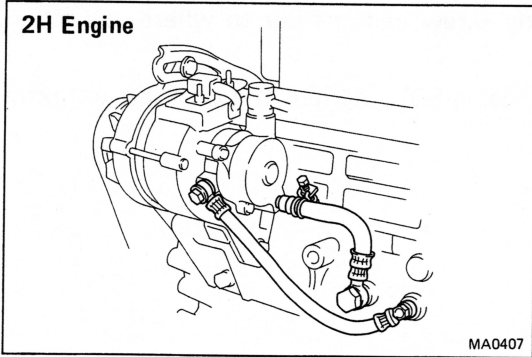

**4. REPLACE VACUUM PUMP OIL HOSES**

- (a) Remove the old oil hoses.
- (b) Install new oil hoses.

After replacing, start the engine and check for oil leaks.

**NOTE:** Check for oil leaks in the next step, after engine oil and oil filter replacement.

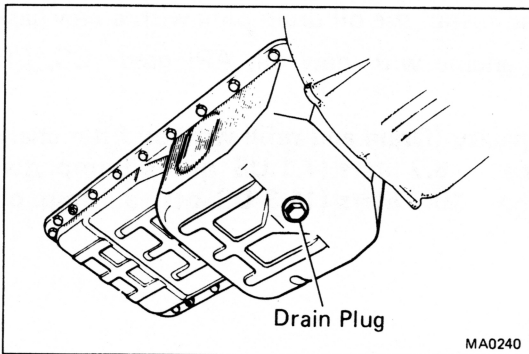

**5. REPLACE ENGINE OIL**

- (a) With the engine warm, remove the oil drain plug and drain the oil.

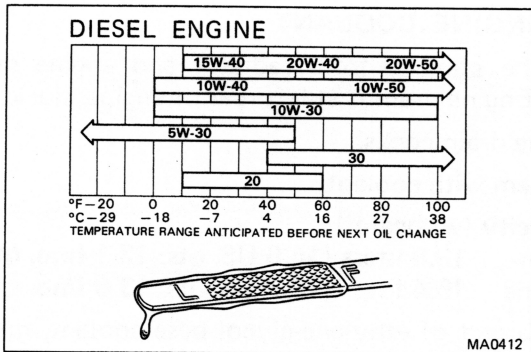

- (b) Clean and install the oil drain plug with the gasket.
- (c) Fill the engine with new oil, API grade CC, CD or better.

**Engine oil capacity (Drain and refill without oil filter change):**

**3B engine** 5.8 liters (6.1 US qts, 5.1 Imp. qts)  
**2H engine** 9.1 liters (9.6 US qts, 8.0 Imp. qts)

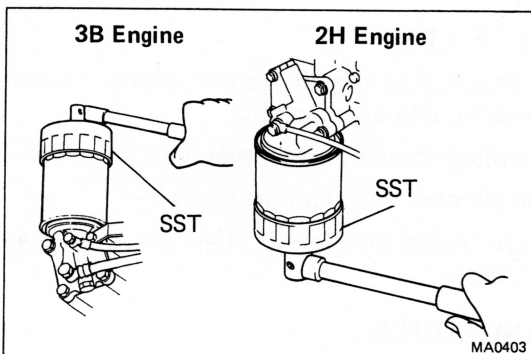

**6. REPLACE ENGINE OIL AND OIL FILTER**

- (a) With the engine warm, remove the oil drain plug and drain the oil.
- (b) Using SST, remove the oil filter (located on the right side of engine block).

SST 3B engine 09228-44011  
 SST 2H engine 09228-60010

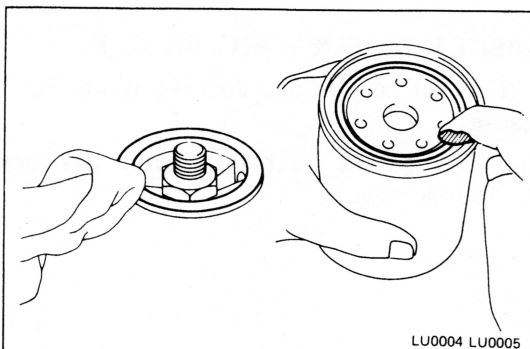

- (c) Install a new oil filter.
  - Inspect and clean the oil filter installation surface.
  - Put a light coat of engine oil on the gasket.



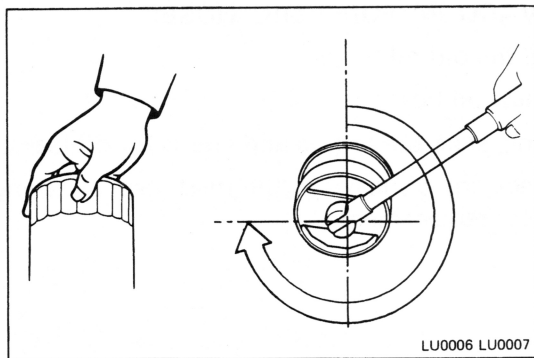

- Lightly screw in the filter to where you feel resistance.
- Then using SST, tighten the oil filter an extra 3/4 turn.

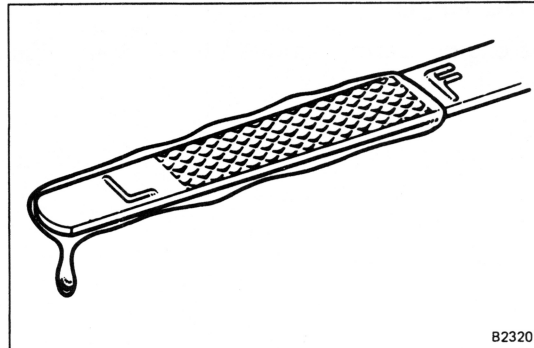

- (d) Clean and install the oil drain plug with a new gasket.
- (e) Fill the engine with new oil, API grade CC, CD or better.

**Engine oil capacity (Drain and refill with oil filter change):**

**3B engine** 6.7 liters (7.1 US qts, 5.9 Imp. qts)  
**2H engine** 10.7 liters (11.3 US qts, 9.4 Imp. qts)

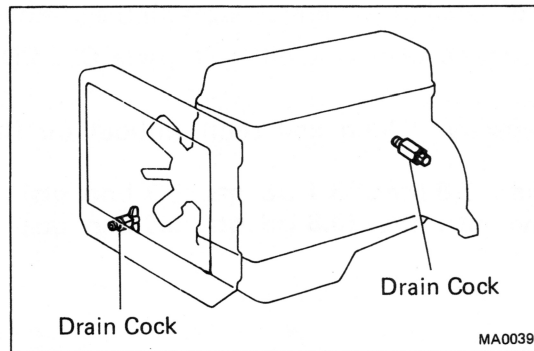

**7. REPLACE ENGINE COOLANT**

- (a) Drain the coolant from radiator and engine drain cocks. (Engine drain is at left rear of engine block.)
- (b) Close the drain cocks.
- (c) Fill system with coolant.

**Coolant capacity (w/ heater):**

**3B engine** 13.8 liters (14.6 US qts, 12.1 Imp. qts)  
**2H engine** 15.4 liters (16.3 US qts, 13.6 Imp. qts)

Use a good brand of ethylene-glycol base coolant, mixed according to the manufacturer's instructions.

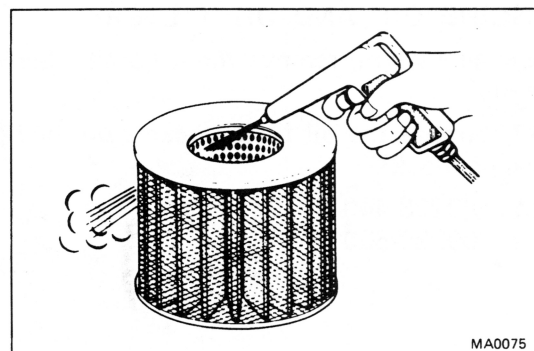

**8. INSPECT AIR FILTER**

- (a) Visually check that the air cleaner element is not excessively dirty, damaged or oily.

If necessary, replace the air cleaner element.

- (b) Clean the element with compressed air.

First blow from inside thoroughly. Then blow off the outside of the element.

**9. REPLACE AIR FILTER**

Replace the used air cleaner element with a new one.

**10. REPLACE GASKET IN FUEL FILLER CAP**

- (a) Remove the four screws and locking plate. Pull out the old gasket.

- (b) Install the new gasket by hand. Install the locking plate with four screws.

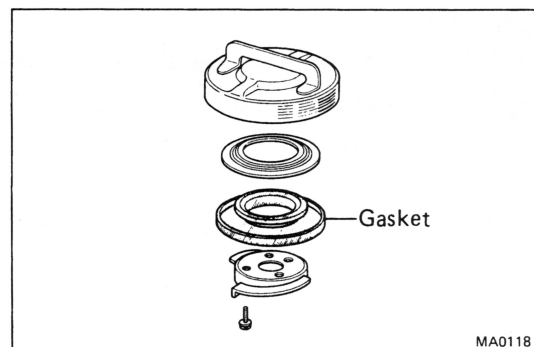

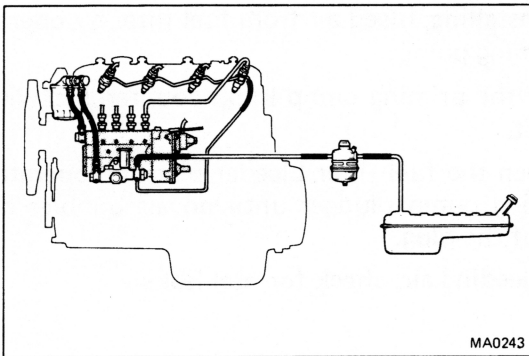

**11. INSPECT FUEL LINES AND CONNECTIONS**

(a) Visually inspect the fuel lines for cracks, leakage loose connections or deformations.

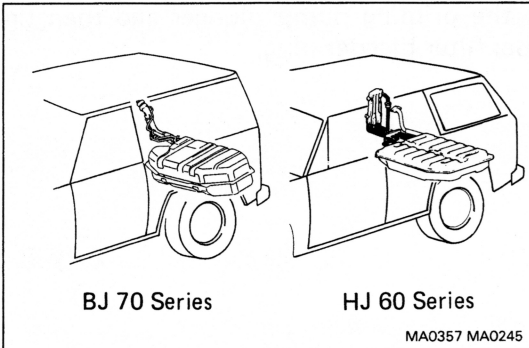

(b) Visually inspect the fuel tank vapor vent system hoses and connections for looseness, sharp bends or damage.

(c) Visually inspect the fuel tank for deformation, cracks fuel leakage or tank band looseness.

(d) Visually inspect the filler neck for damage or fuel leakage.

**12. INSPECT EXHAUST PIPES AND MOUNTINGS**

Visually inspect the pipes, hangers, and connections for severe corrosion, leaks or damage.

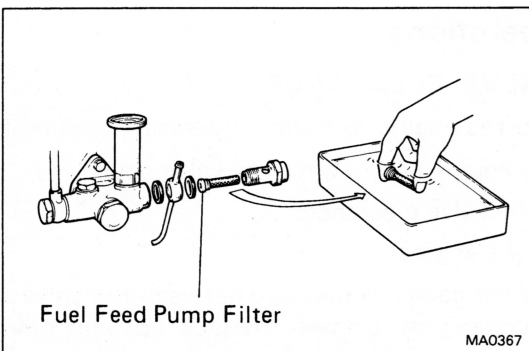

**13. INSPECT FUEL FEED PUMP FILTER**

(a) Remove the inlet union bolt from the feed pump.

(b) Remove the filter from the union bolt.

(c) Clean the filter and check the damage.

(d) Install the filter to the union bolt.

(e) Install the union bolt to the feed pump with a new gasket.

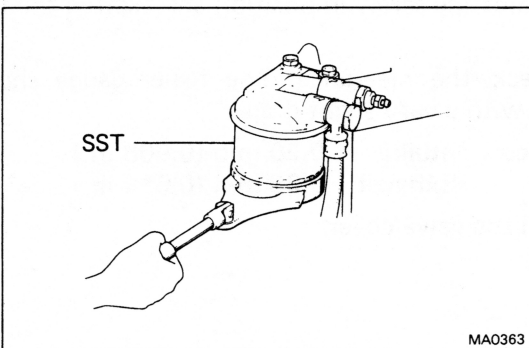

**14. REPLACE FUEL FILTER**

(a) Using SST, remove the fuel filter (located on the intake manifold).

SST 09228-34010

(b) Install a new fuel filter.

- Put a light coat of fuel on the gasket.

- Hand tighten ONLY. DO NOT use a wrench to tighten the filter.

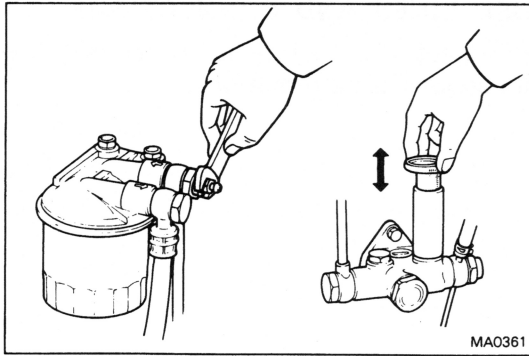

MA0361

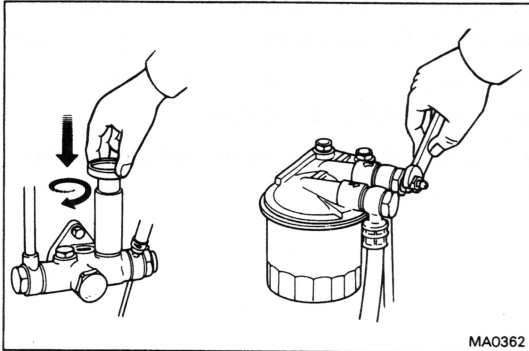

MA0362

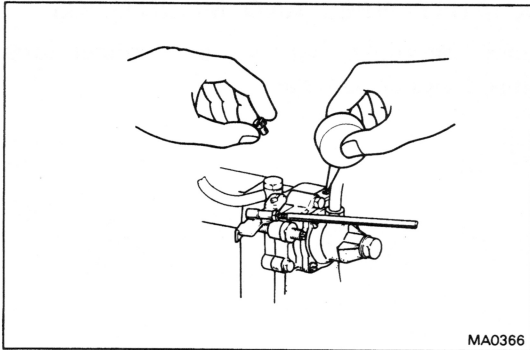

MA0366

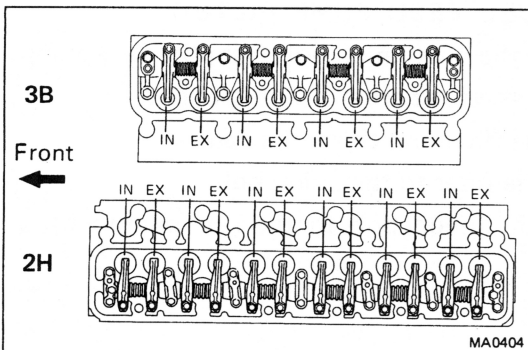

MA0404

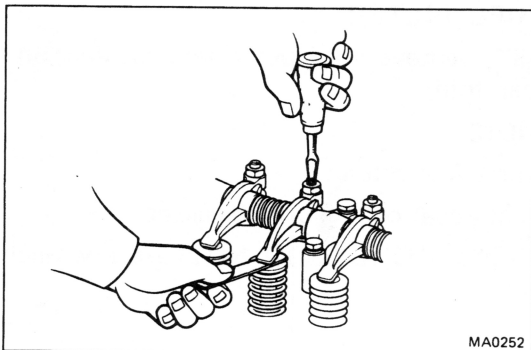

MA0252

- (c) After installing, bleed air from fuel filter by operating the priming pump.
  - Turn the priming pump knob counterclockwise to free it.
  - Loosen the fuel filter bleeder plug and operate the priming pump plunger until no air bubbles come out of the plug.
- (d) After bleeding air, check for fuel leaks.
  - Lock the priming pump plunger and then tighten the fuel filter bleeder plug.

## 15. INSPECT INJECTION PUMP GOVERNOR DIAPHRAGM OIL

- (a) Remove the screw plug from the governor housing.
- (b) Supply the diaphragm with 2 – 4 drops of the proper diaphragm oil.

Recommended diaphragm oil:

ND Part No. 995500-0140

BOSCH Part No. OL-36V1

## Hot Engine Operations

### 16. ADJUST VALVE CLEARANCE

- (a) Warm up the engine to normal operating temperature.
- (b) Stop the engine and remove the valve cover.
- (c) Adjust the valve clearance.
  - Start the engine.
  - Use feeler gauge to measure between the valve stem and rocker arm. Loosen the lock nut and turn the adjusting screw to set the proper clearance. Hold the adjusting screw in position and tighten the lock nut.
  - Recheck the clearance. The feeler gauge should move with a very slight drag.

Valve clearance: Intake 0.20 mm (0.008 in.)  
Exhaust 0.36 mm (0.014 in.)

- (d) Reinstall the valve cover.

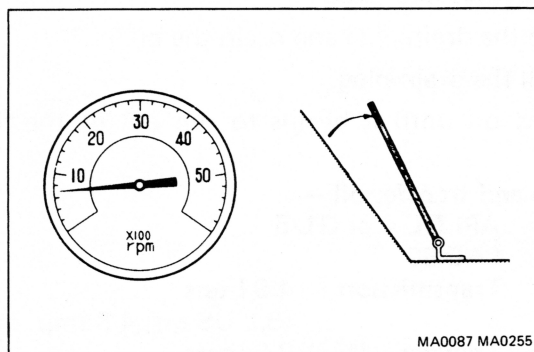
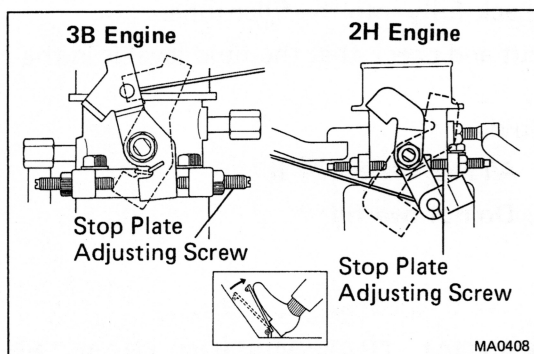
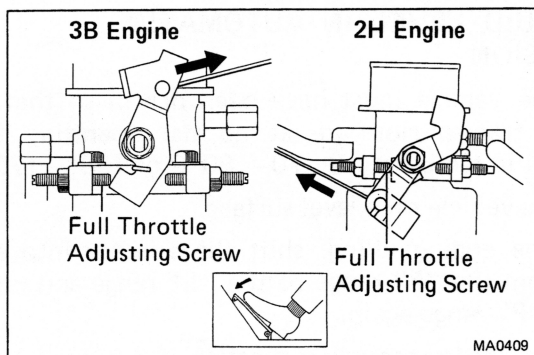

### 17. ADJUST IDLE SPEED

- (a) Initial conditions:
  - Air cleaner installed
  - Engine coolant normal operating temperature
  - Accessories switched off
  - Transmission in neutral
- (b) Check that the venturi lever touches the full throttle adjusting screw when the accelerator pedal is depressed all the way.
- (c) Check that the venturi lever touches the stop plate adjusting screw when the accelerator pedal is released. If not, adjust the accelerator linkage.

- (d) Install a tachometer to the engine.
- (e) Start the engine.
- (f) Check the engine idle speed.

Idle speed: 3B engine 650 rpm  
 2H engine (M/T) 650 rpm  
 (A/T) 750 rpm

If not specified, adjust by turning the stop plate adjusting screw.

### TRANSMISSION

#### 18. CHECK OIL LEVEL IN MANUAL TRANSMISSION, TRANSFER AND DIFFERENTIAL

Remove the filler plug and feel inside the hole with your finger. Check that the oil comes to within 5 mm (0.20 in.) of the bottom edge of the hole. If the level is low, add oil until it begins to run out of the filler hole.

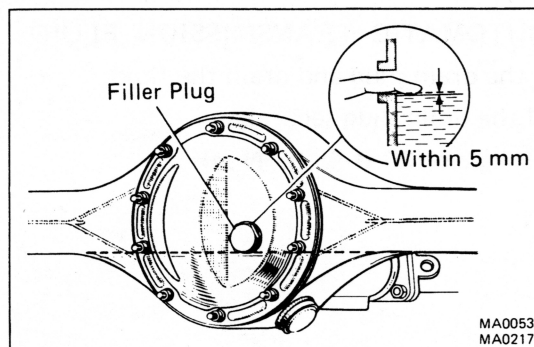
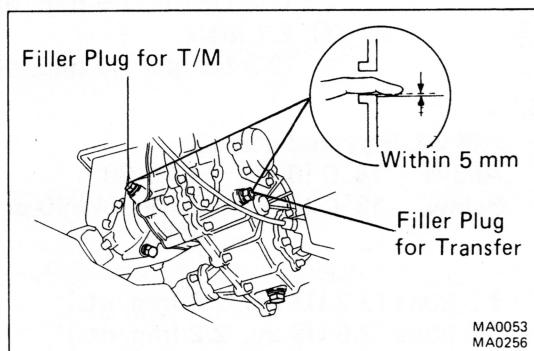



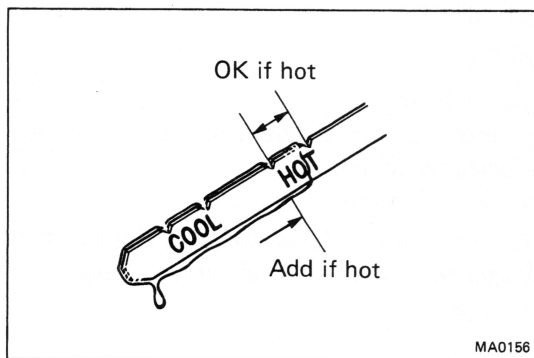

## 19. CHECK FLUID LEVEL IN AUTOMATIC TRANSMISSION

NOTE: The vehicle must have been driven so that the engine and transmission are at normal operating temperature. (fluid temperature: 70 – 80°C or 158 – 176°F)

- Park the vehicle on a level surface.
- With the engine idling, shift the selector into each gear from the "P" range to the "L" range and return to the "P" range again.
- Pull out the transmission dipstick and wipe it clean.
- Push it back fully into the filler tube.
- Pull it out and check that the fluid level is in the HOT range.

If low, add fluid.

Fluid type: ATF DEXRON® II

CAUTION: Do not overfill.

## 20. REPLACE MANUAL TRANSMISSION, TRANSFER AND DIFFERENTIAL OIL

- Remove the drain plug and drain the oil.
- Reinstall the drain plug.
- Add new oil until it begins to run out of the filler hole.

Transmission and transfer oil –

Oil grade: API GL-4 or GL-5

Viscosity: SAE 90

Capacity:	Transmission	4.9 liters (5.2 US qts, 4.3 Imp. qts)
	Transfer (M/T)	2.2 liters (2.3 US qts, 1.9 Imp. qts)
	(A/T)	2.1 liters (2.2 US qts, 1.8 Imp. qts)

Differential oil –

Oil grade: API GL-5 hypoid gear oil

Viscosity:	Above -18°C (0°F)	SAE 90
	Below -18°C (0°F)	SAE 80W-90 or 80W

Capacity:

Front	3.0 liters (3.2 US qts, 2.6 Imp. qts)
Rear	2.5 liters (2.6 US qts, 2.2 Imp. qts)

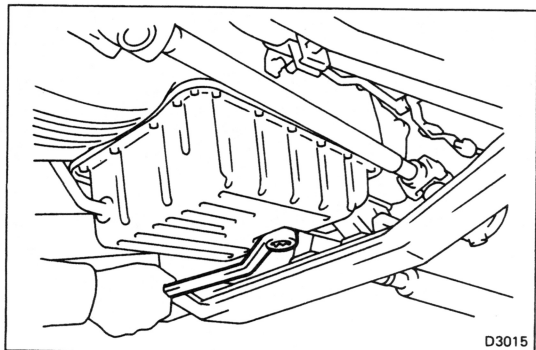
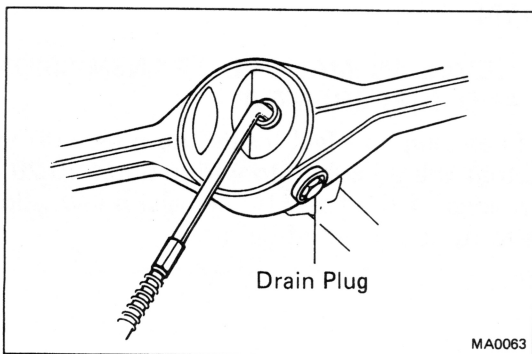
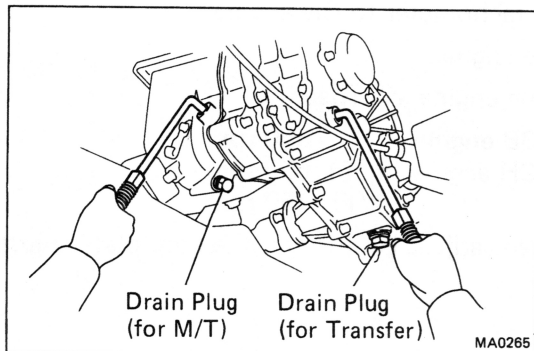

## 21. REPLACE AUTOMATIC TRANSMISSION FLUID

- Remove the drain plug and drain the fluid.
- Reinstall the drain plug securely.

Torque: 280 kg-cm (20 ft-lb, 27 N-m)

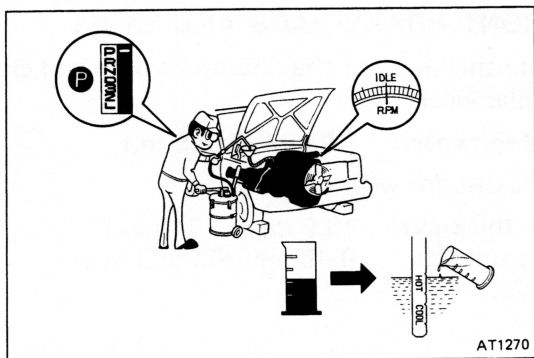

(c) Pour ATF through the filler tube.

**Fluid: ATF DEXRON® II**

(d) With the engine idling, shift the selector into each gear from the "P" range to the "L" range and return to the "P" range again.

(e) With the engine idling, check the fluid level. Add fluid up to the "COOL" level on the dipstick.

(f) Check the fluid level with the normal fluid temperature (70 – 80°C or 158 – 176°F) and add as necessary.

**CAUTION: Do not overfill.**

**Drain and refill capacity:**

**5.0 liters (5.3 US qts, 4.4 Imp. qts)**

**Dry fill capacity:**

**15.0 liters (15.9 US qts, 13.2 Imp. qts)**

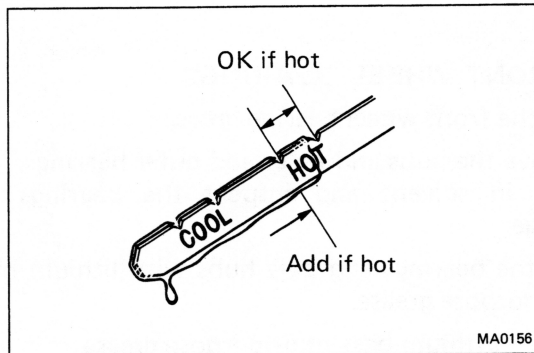

## BRAKES

### 22. INSPECT BRAKE LINE PIPES AND HOSES

**NOTE:** Inspect in a well lighted area. Inspect the entire circumference and length of the brake hoses using a mirror as required. Turn the front wheels fully right or left before inspecting the front brake.

(a) Check all brake lines and hoses for:

- Damage
- Wear
- Deformation
- Cracks
- Corrosion
- Leaks
- Bends
- Twists

(b) Check all clamps for tightness and connections for leakage.

(c) Check that the hoses and lines are clear of sharp edges, moving parts and the exhaust system.

(d) Check that the lines installed in grommets pass through the center of the grommets.

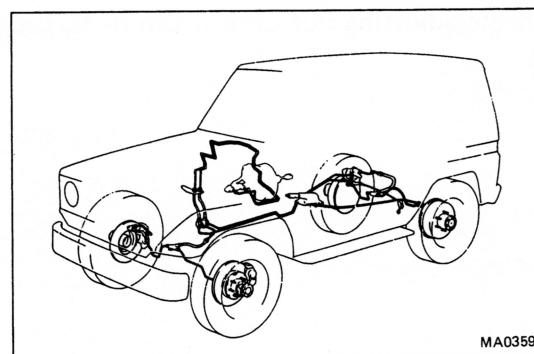
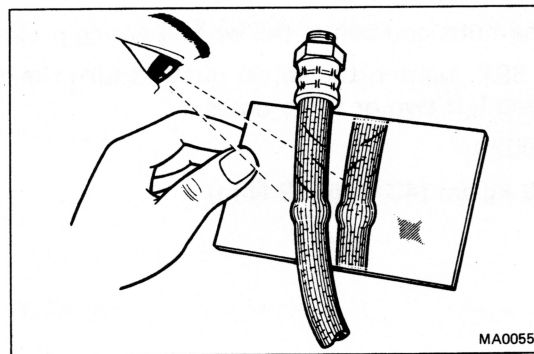

### 23. INSPECT REAR BRAKE LININGS AND DRUMS

(a) Check the linings for wear.

**Minimum lining thickness: 1.5 mm (0.059 in.)**

(b) Check the brake drums for scoring or wear.

**Maximum drum inside diameter: 297 mm (11.69 in.)**

(c) Clean the brake parts with a damp cloth.

**NOTE:** Do not use compressed air to clean the brake parts.

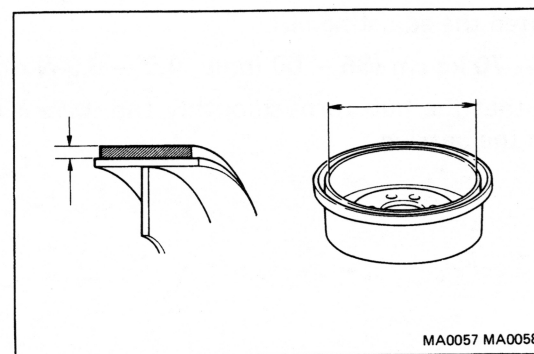

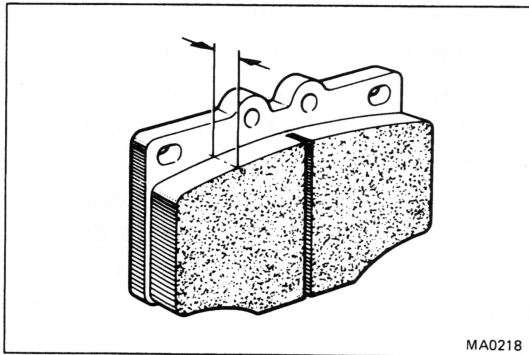

MA0218

## 24. INSPECT FRONT BRAKE PADS AND DISCS

- (a) Check the thickness of the disc brake pads and check for irregular wear.

**Minimum pad thickness: 1.0 mm (0.039 in.)**

- (b) Check the disc for wear or runout.

**Minimum disc thickness: 19.0 mm (0.748 in.)**

**Maximum disc runout: 0.15 mm (0.0059 in.)**

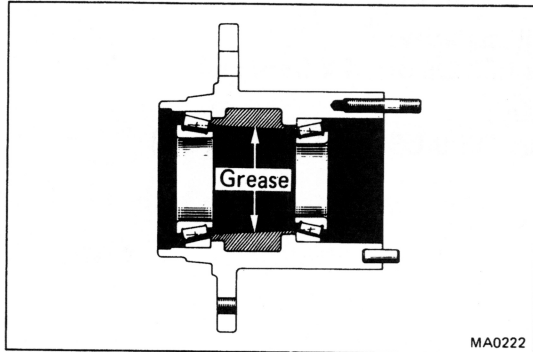

MA0222

## CHASSIS

### 25. REPACK FRONT WHEEL BEARINGS

- (a) Change the front wheel bearing grease.

- Remove the hubs and inner and outer bearings. Clean in solvent and inspect the bearings for damage.
- Pack the bearings and axle hubs with lithium base multipurpose grease.

**Grease grade: Lithium base multipurpose grease (NLGI No. 2)**

- (b) Install the hubs and adjust the wheel bearing preload.

- Using SST, tighten the adjust nut and turn the hub right and left two or three times.

**SST 09607-60020**

**Torque: 600 kg-cm (43 ft-lb, 59 N·m)**

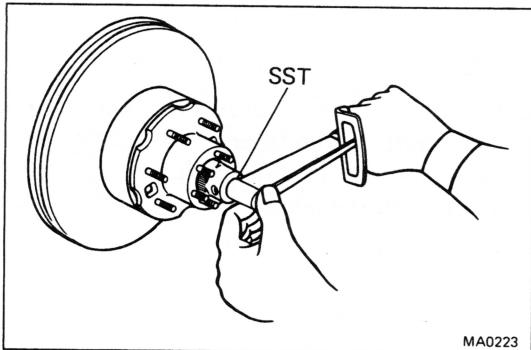

MA0223

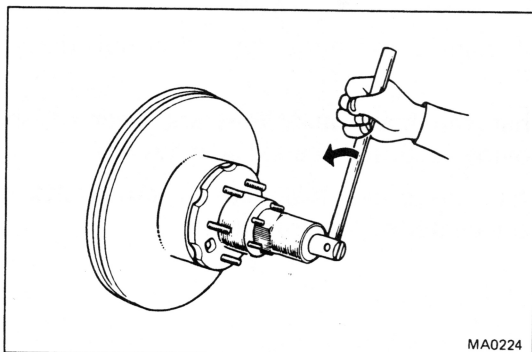

MA0224

- Loosen the adjusting nut until it can be turned by hand.

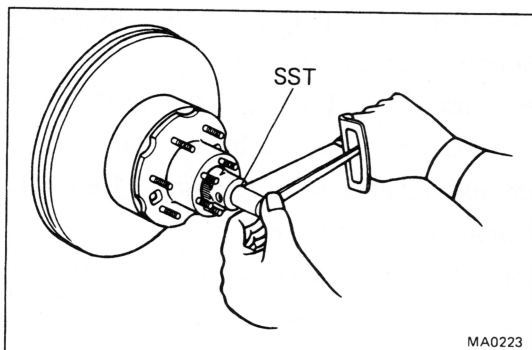

MA0223

- Retighten the adjusting nut.

**Torque: 40 – 70 kg-cm (35 – 60 in.-lb, 4.0 – 6.8 N·m)**

- Insure that the hub turns smoothly and there is no play in the bearing.

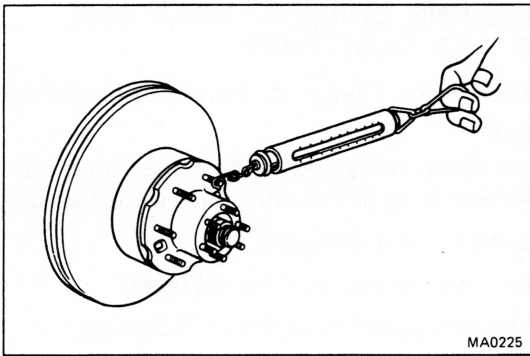

- Using a spring tension gauge, check for correct preload.

**Front wheel bearing friction preload (at starting point):**  
**0.4 – 3.3 kg (0.9 – 7.3 lb, 4 – 32 N)**

If the preload is incorrect, loosen or tighten the nut to correct the preload.

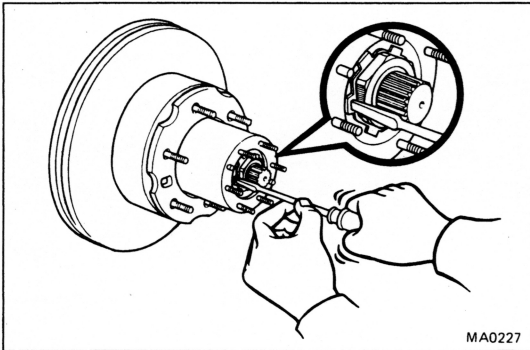

- (c) Install the lock washer and lock nut.  
 (d) Lock the adjusting nut by bending one of the lock washer teeth inward.

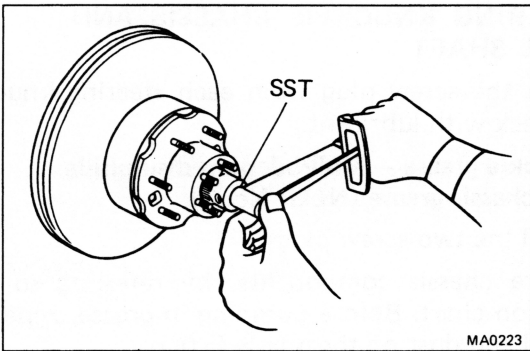

- (e) Using SST, tighten the lock nut.

SST 09607-60020

**Torque: 800 kg-cm (58 ft-lb, 78 N·m)**

- (f) Lock the lock nut by bending one of the lock washer teeth outward.

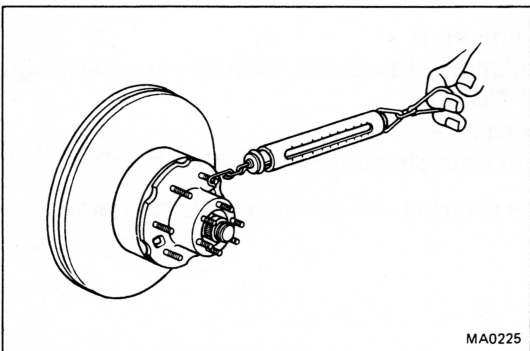

- (g) Recheck the preload at the hub bolt.

**Front wheel bearing friction preload (at starting point):**  
**0.4 – 3.3 kg (0.9 – 7.3 lb, 4 – 32 N)**



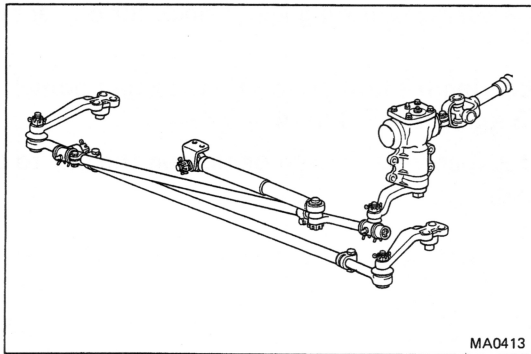

## 26. INSPECT STEERING LINKAGE, GEAR BOX, BALL JOINT AND DUST COVER

- (a) Check the steering linkage for looseness or damage.  
Check that:
  - Tie rod ends, relay rod ends, center arm, shimmy damper and drag link do not have excessive play.
  - Dust seals are not damaged.
- (b) Check the steering gear box for oil leaks.
- (c) Inspect the ball joint for excessive looseness.
- (d) Inspect the dust cover for damage.

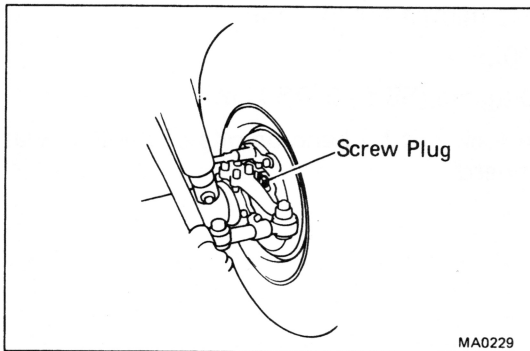

## 27. LUBE STEERING KNUCKLE, CHASSIS AND PROPELLER SHAFT

- (a) Remove the screw plug from each steering knuckle and repack with lubricant.

**Steering knuckle grease – Molybdenum disulphide lithium base chassis grease (NLGI No. 2)**

- (b) Reinstall the two screw plugs.
- (c) Lubricate chassis components, by referring to the lubrication chart. Before pumping in grease, wipe off any mud and dust on the grease fitting.

**Grease grade:**

**Steering link ends –**

**Molybdenum disulphide lithium base chassis grease (NLGI No. 2)**

**Propeller shaft –**

**Lithium base chassis grease (NLGI No. 2)**

- (d) Check the steering linkage dust seals for damage.

BJ70 Series

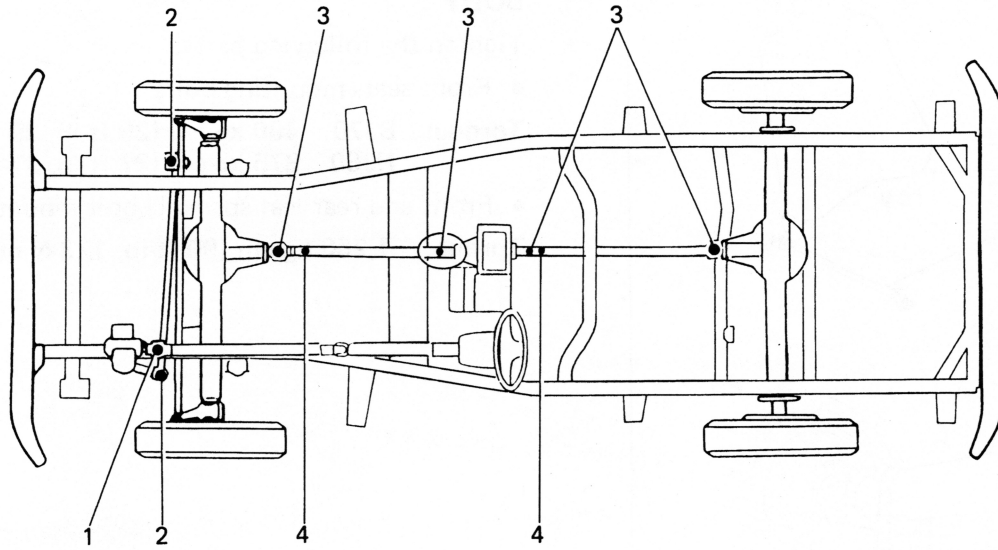

Lubrication Positions:

- |                  |                 |
|------------------|-----------------|
| Steering         | Propeller Shaft |
| 1. Slide Yoke    | 3. Spider       |
| 2. Relay Rod End | 4. Slide Yoke   |

MA0355

HJ60 Series

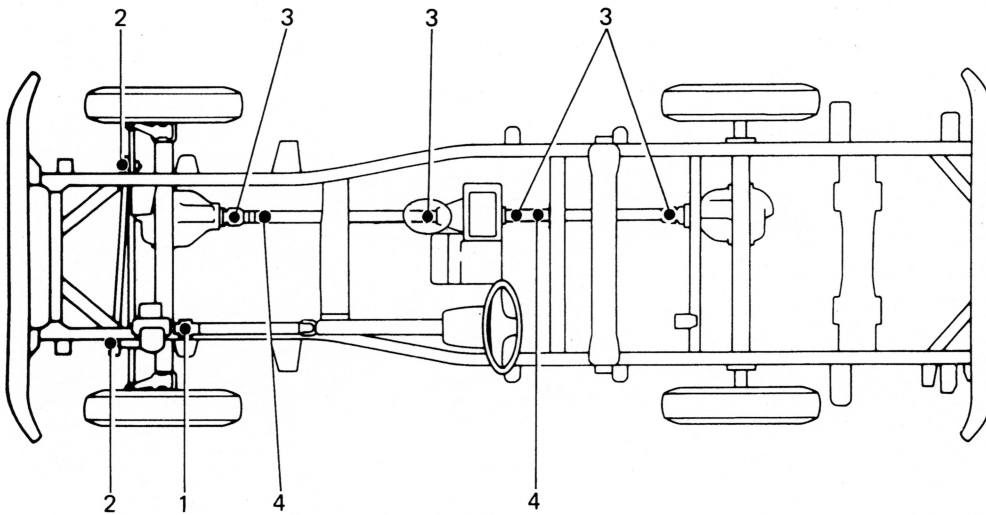

Lubrication Positions:

- |                  |                 |
|------------------|-----------------|
| Steering         | Propeller Shaft |
| 1. Slide Yoke    | 3. Spider       |
| 2. Relay Rod End | 4. Slide Yoke   |

MA0262

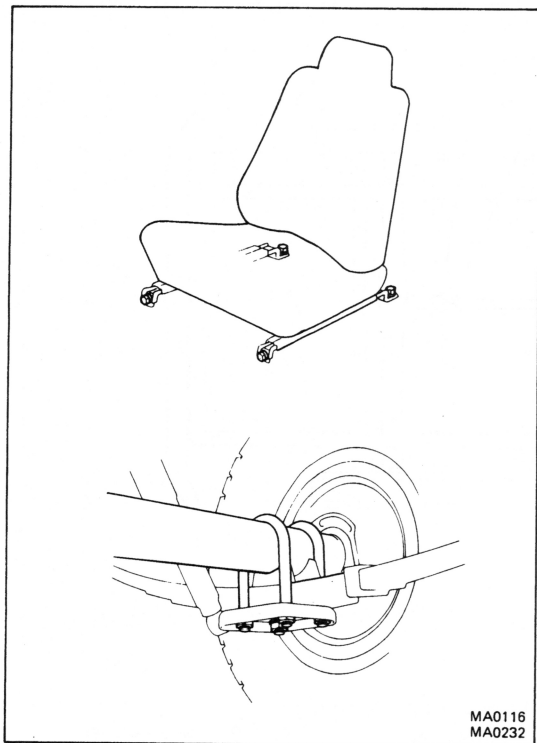

## 28. TIGHTEN BOLTS AND NUTS ON CHASSIS AND BODY

Tighten the following parts:

- Front seats mounting bolts

Torque: BJ70 400 kg-cm (29 ft-lb, 39 N·m)

HJ60 375 kg-cm (27 ft-lb, 37 N·m)

- Front and rear leaf spring U-bolt mounting nuts

Torque: 1,250 kg-cm (90 ft-lb, 123 N·m)

---

# APPENDIX

	Page
GENERAL MAINTENANCE .....	A-2

**A**



## GENERAL MAINTENANCE

These are the maintenance and inspections items which are considered to be the owner's responsibility. They can be performed by the owner or they can have them done at a service shop. These items include those which should be checked on a daily basis, those which, in most cases, do not require (special) tools and those which are considered to be reasonable for the owner to perform.

Items and procedures for general maintenance are as follows.

### OUTSIDE VEHICLE

#### 1. TIRES

- (a) Check the pressure with a gauge. If necessary, adjust.
- (b) Check for cuts, damage or excessive wear.

#### 2. WHEEL NUTS

When checking the tires, check the nuts for looseness or for missing nuts. If necessary, tighten them.

#### 3. TIRE ROTATION

It is recommended that tires be rotated every 7,500 miles (12,000 km).

#### 4. WINDSHIELD WIPER BLADES

Check for wear or cracks whenever they do not wipe clean. If necessary, replace.

#### 5. FLUID LEAKS

- (a) Check underneath for leaking fuel, oil, water or other fluid.
- (b) If you smell gasoline fumes or notice any leak, have the cause found and corrected.

#### 6. DOORS AND ENGINE HOOD

- (a) Check that all doors including the back door operate smoothly, and that all latches lock securely.
- (b) Check that the engine hood secondary latch secures the hood from opening when the primary latch is released.

### INSIDE VEHICLE

#### 7. LIGHTS

- (a) Check that the headlights, stop lights, taillights, turn signal lights, and other lights are all working.

- (b) Check the headlight aim.

#### 8. WARNING LIGHTS AND BUZZERS

Check that all warning lights and buzzers function properly.

#### 9. HORN

Check that it is working.

#### 10. WINDSHIELD GLASS

Check for scratches, pits or abrasions.

#### 11. WINDSHIELD WIPER AND WASHER

- (a) Check operation of the wipers and washer.
- (b) Check that the wipers do not streak.

#### 12. WINDSHIELD DEFROSTER

Check that air comes out from the defroster outlet when operating the heater or air conditioner.

#### 13. REAR VIEW MIRROR

Check that it is mounted securely.

#### 14. SUN VISORS

Check that they move freely and are mounted securely.

#### 15. STEERING WHEEL

Check that it has specified freeplay. Be alert for changes in steering condition, such as hard steering, excessive freeplay or strange noise.

#### 16. SEATS

- (a) Check that all front seat controls such as seat adjusters, seatback recliner, etc. operate smoothly.
- (b) Check that all latches lock securely in any position.
- (c) Check that the locks hold securely in any latched position.
- (d) Check that the head restraints move up and down smoothly and that the locks hold securely in any latched position.
- (e) For folding-down rear seat backs, check that the latches lock securely.

#### 17. SEAT BELTS

- (a) Check that the seat belt buckles, retractors and anchors operate properly and smoothly.

- (b) Check that belt webbing is not cut, frayed, worn or damaged.

#### 18. ACCELERATOR PEDAL

Check the pedal for smooth operation and uneven pedal effort or catching.

#### 19. CLUTCH PEDAL

- (a) Check the pedal for smooth operation.
- (b) Check the clutch booster function.

#### 20. BRAKE PEDAL

- (a) Check the pedal for smooth operation.
- (b) Check the brake booster function.

#### 21. BRAKES

At a safe place, check that the brakes do not pull to one side when applied.

#### 22. PARKING BRAKE

- (a) Check that the lever has the proper travel.
- (b) On a safe incline, check that vehicle is held securely with only the parking brake applied.

### UNDER HOOD

#### 23. WINDSHIELD WASHER FLUID

Check that there is sufficient fluid in the tank.

#### 24. ENGINE COOLANT LEVEL

Check that the coolant level is between the "FULL" and "LOW" lines on the see-through reservoir.

#### 25. RADIATOR AND HOSES

- (a) Check that the front of the radiator is clean and not blocked with leaves, dirt or bugs.
- (b) Check the hoses for cracks, kinks, rot or loose connections.

#### 26. BATTERY ELECTROLYTE LEVEL

Check that the electrolyte level of all battery cells is between the upper and lower level lines on the case. If level is low, and distilled water only.

#### 27. BRAKE AND CLUTCH FLUID LEVELS

- (a) Check that the brake fluid level is near the upper level line on the see-through reservoir.
- (b) Check that the clutch fluid level is up to the top of the narrow neck of the see-through reservoir.

#### 28. ENGINE DRIVE BELTS

Check all drive belts for fraying, cracks, wear or oiliness.

#### 29. ENGINE OIL LEVEL

Check the level on the dipstick with the engine turned off.

#### 30. POWER STEERING FLUID LEVEL

Check the level on the dipstick. The level should be in the "HOT" or "COLD" range depending on the fluid temperature.

#### 31. EXHAUST SYSTEM

Visually inspect for cracks, holes or loose supports. If any change in the sound of the exhaust or smell of the exhaust fumes is noticed, have the cause located and corrected.